

RECIPROCATING MACHINES



- Shaping, planing and slotting can be defined as the process of removing metal from a surface in horizontal, vertical and inclined position to produce a flat or plane surface, slots and grooves by means of a relative reciprocating motion between the tool and work piece.

- Difference between the three processes of shaping, planing and slotting is that in shaping and slotting, the tool is reciprocating and the work piece is fed in to the cutting tool while in planing, the work piece is reciprocating and the tool is fed in.

- Tool reciprocates horizontally in the shaping and vertically in slotting.

- Cutting is intermittent in all the three processes because in the relative reciprocating motion the tool cuts only in forward- working (or cutting) stroke followed by the idle-return stroke.

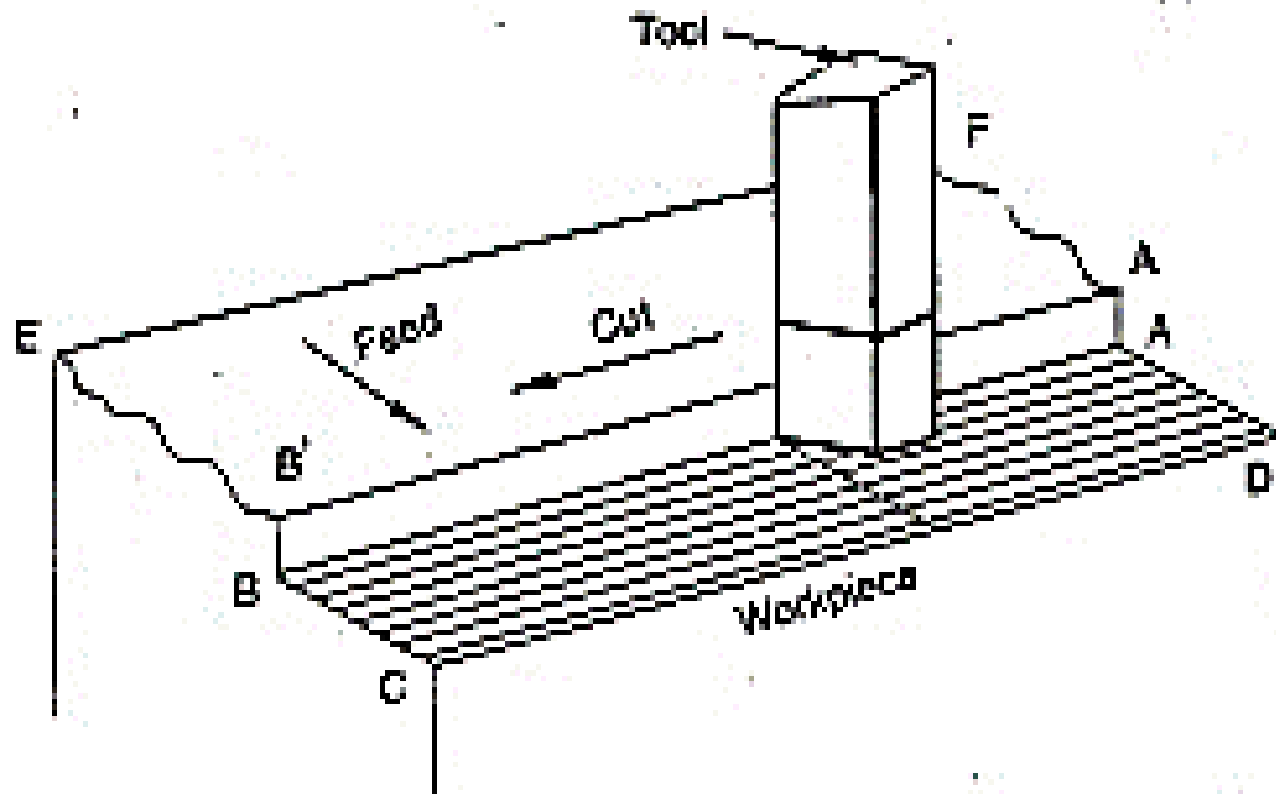

Figure 7.1 Process of producing a flat surface.

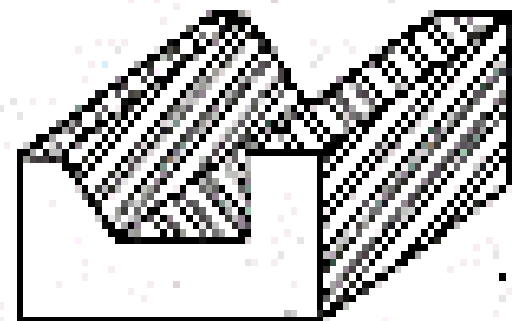
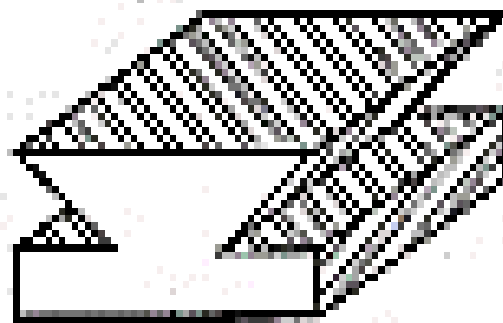
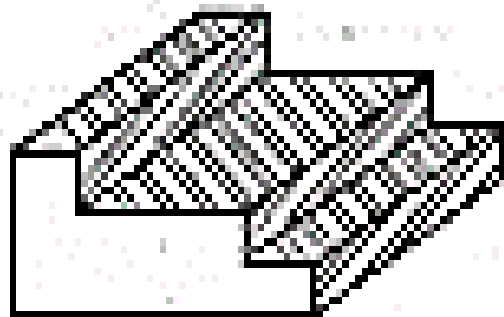
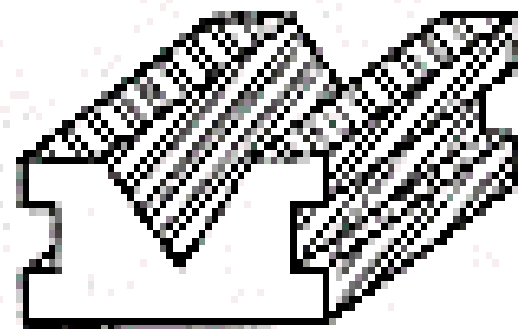
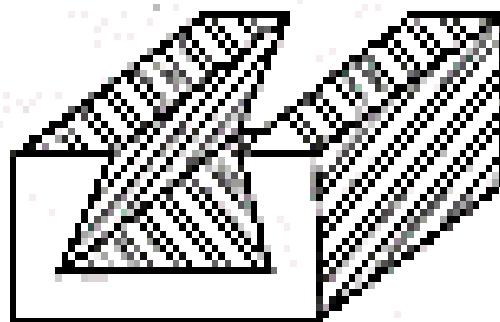
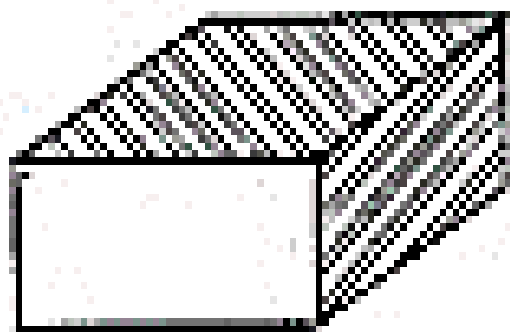

Figure 7.2 Components manufactured by the shaping process.

The Shaper

- Machine tool used for shaping operation is called shaper.
- Designed for machining flat surfaces on small sized jobs. If the size of the job is large, then planing is used.
- In a shaper , the work piece is held stationary during cutting, while the tool reciprocates horizontally. the feed and depth of cut are normally provided by moving the work. Such shaper is called a horizontal shaper.

Shaper is a machine tool used primarily for:

1. Producing a flat or plane surface which may be in a horizontal, a vertical or an angular plane.
2. Making slots, grooves and keyways
3. Producing contour of concave/convex or a combination of these



Cutting tool in action

Photographic view of a shaping machine

Working Principle:

- Job is rigidly fixed on the machine table.
- Single point cutting tool held properly in the tool post is mounted on a reciprocating ram.
- Reciprocating motion of the ram is obtained by a quick return motion mechanism.
- As the ram reciprocates, the tool cuts the material during its forward stroke.
- During return, there is no cutting action and this stroke is called the idle stroke.
- Forward and return strokes constitute one operating cycle of the shaper.

SHAPER

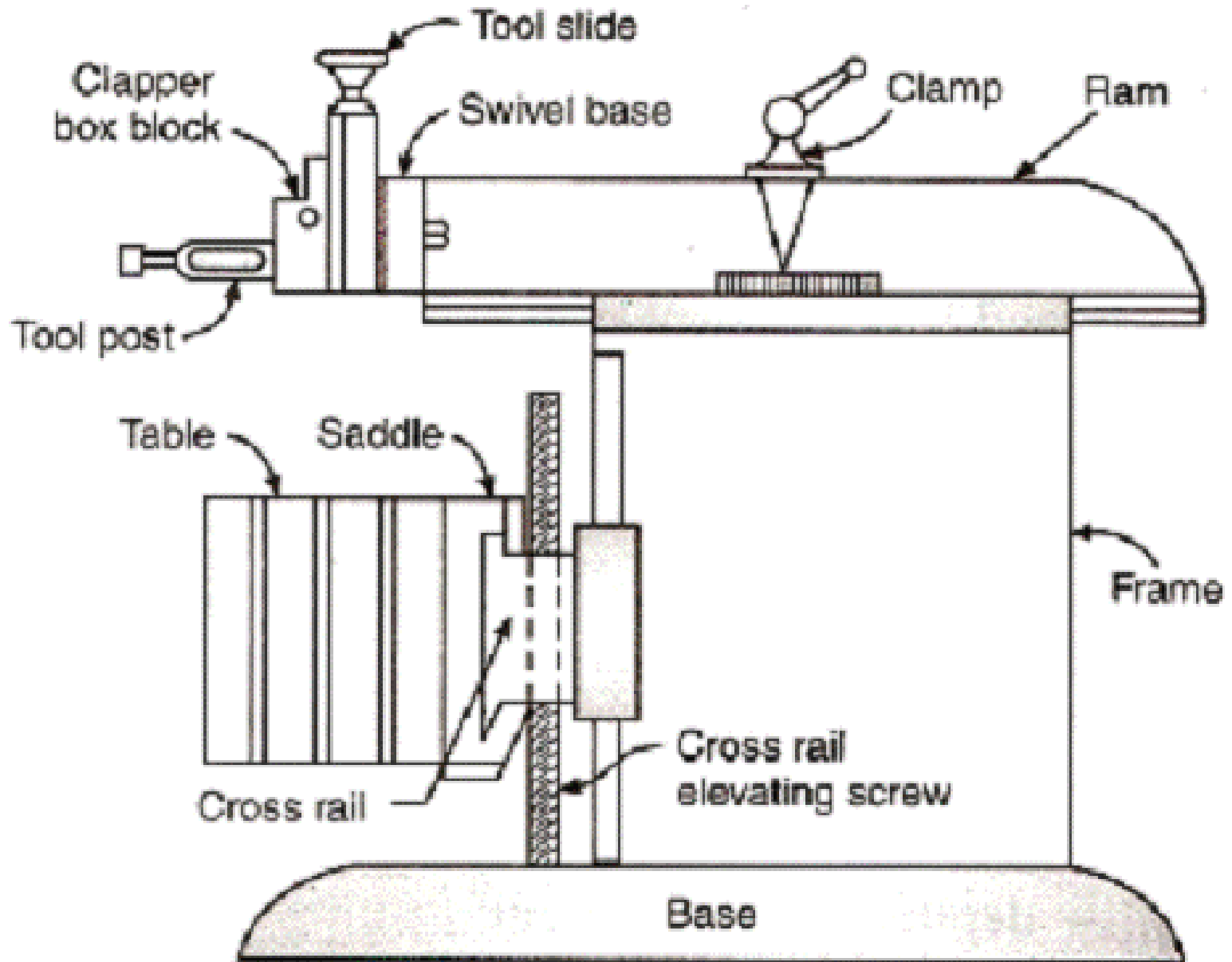

Construction:

The main parts of the Shaper machine is

- Base
- Body (Pillar, Frame, Column)
- Cross rail, Ram
- tool head (Tool Post, Tool Slide, Clamper Box Block)

Base:

- Base is a heavy cast iron casting which is fixed to the shop floor.
- It supports the body frame and the entire load of the machine.
- Base absorbs and withstands vibrations and other forces which are likely to be induced during the shaping operations.

Body (Pillar, Frame, Column):

- It is mounted on the base and houses the drive mechanism comprising the main drives, the gear box and the quick return mechanism for the ram movement.
- The top of the body provides guide ways for the ram and its front provides the guide ways for the cross rail.

Cross rail:

- Mounted on the front of the body frame and can be moved up and down.
- The vertical movement of the cross rail permits jobs of different heights to be accommodated below the tool.
- Sliding along the cross rail is a saddle which carries the work table.

Ram and tool head:

- Ram is driven back and forth in its slides by the slotted link mechanism.
- The back and forth movement of ram is called stroke and it can be adjusted according to the length of the workpiece to be-machined.

Types of Shaping Machines

- Shaping machines are the reciprocating type of machine tools in which the work piece is held stationary and the tool reciprocates.
- Most shapers have reciprocating motion in horizontal position (horizontal shapers) but shapers are also designed with reciprocating motion in vertical position (vertical shapers) or slotting machines or slotters.

The Shaping Operation

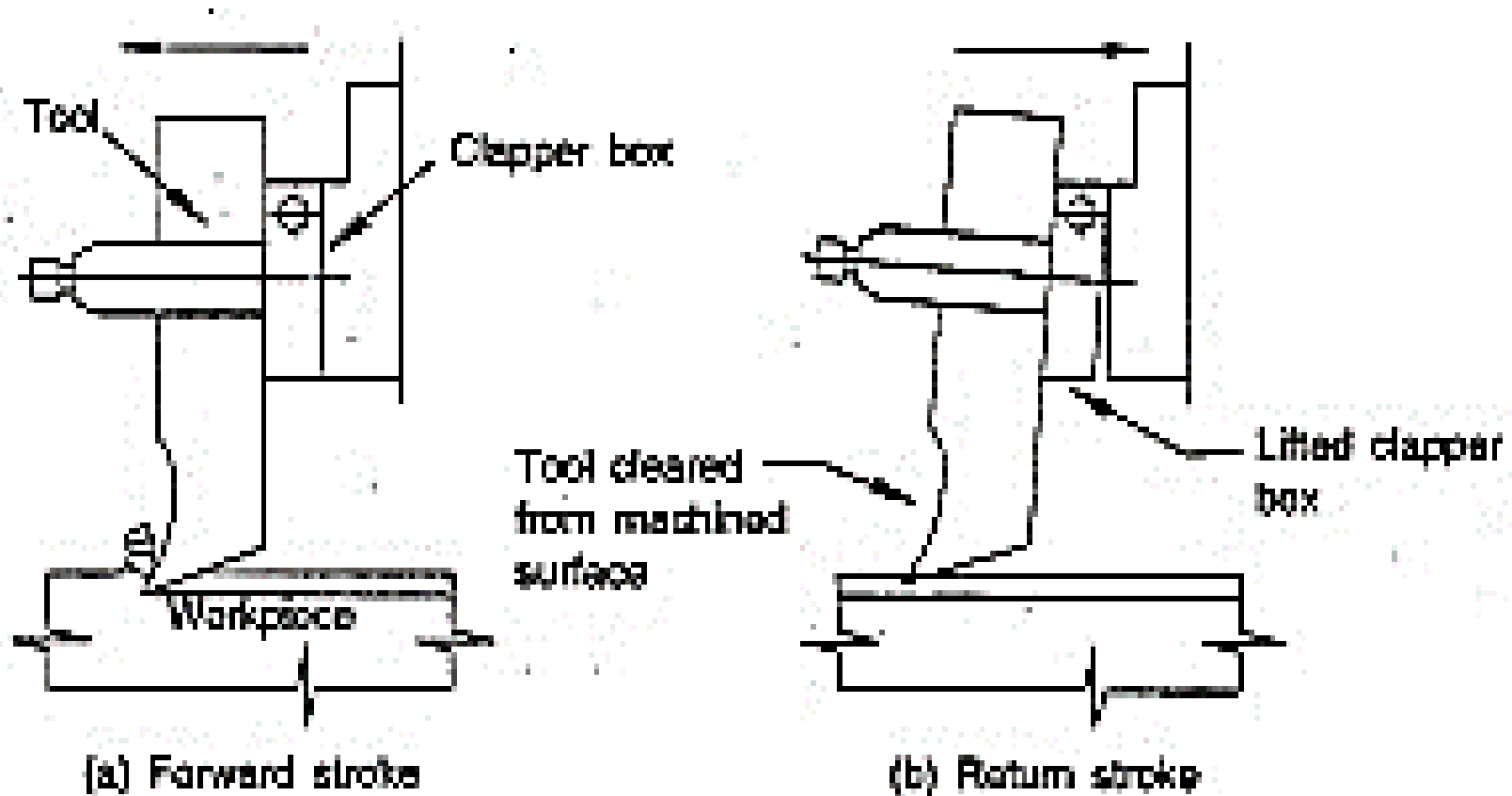

Figure 7.4 The cutting action and functioning of clapper box in a shaper.

Quick Return Mechanism

Ram moves at a comparatively slower speed during the forward cutting stroke.

During the return stroke, the mechanism is so designed to make the tool move at a faster rate to reduce the idle return time.

This mechanism is known as quick return mechanism.

As the ram moves at a faster rate during return stroke, the time taken becomes less. The total machining time decreases and the rate of production increases. The following mechanisms are used for quick return of the ram.

1. Crank and slotted link mechanism

2. Hydraulic mechanism

3. Whitworth mechanism

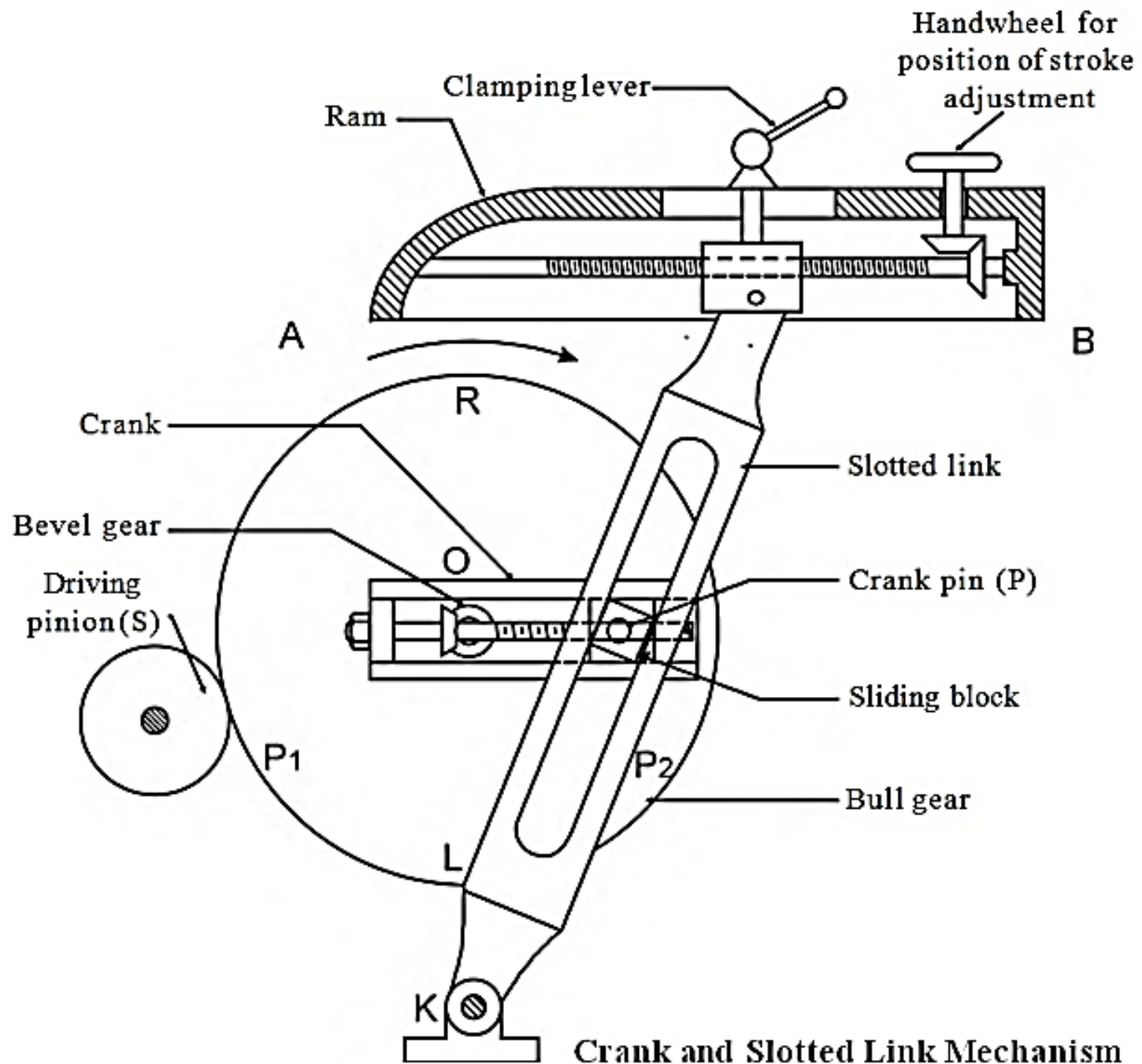

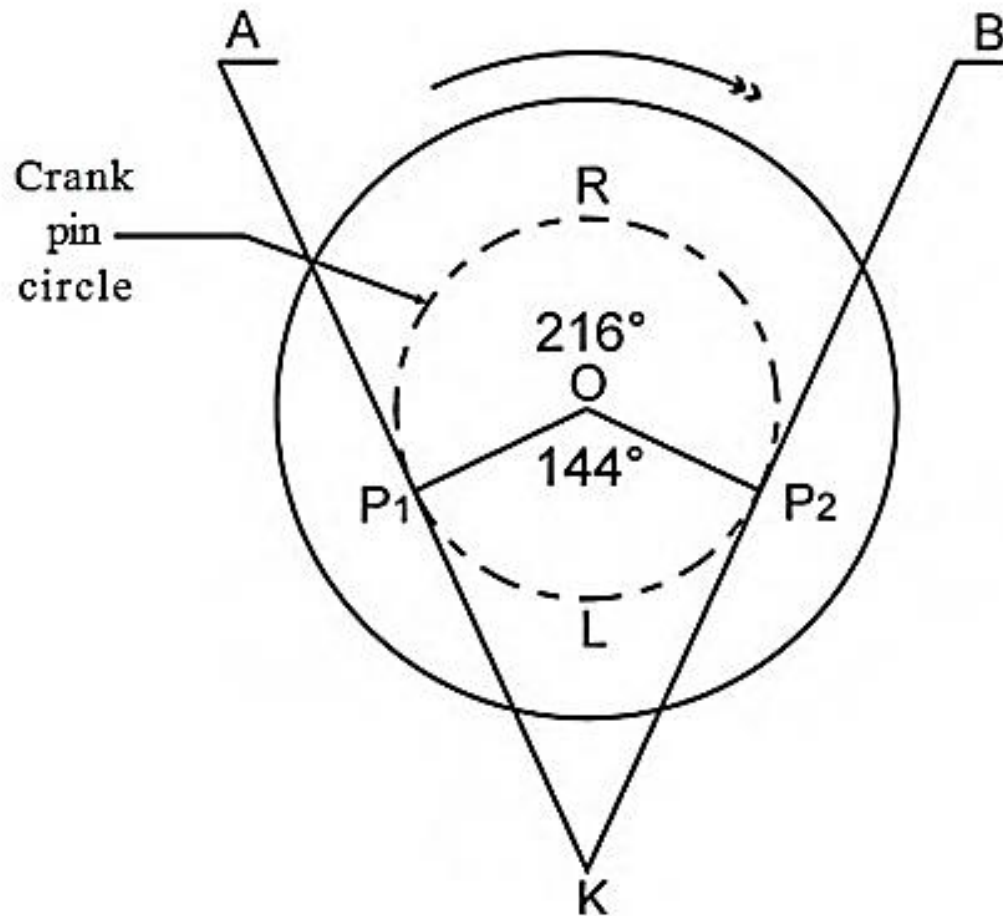

Quick Return Mechanism of the Ram

Stroke length of a ram is the distance the ram moves forward or backward. It depends upon the distance between the centre of the bull gear and the centre of the sliding block. It is adjusted according to the length of the work.

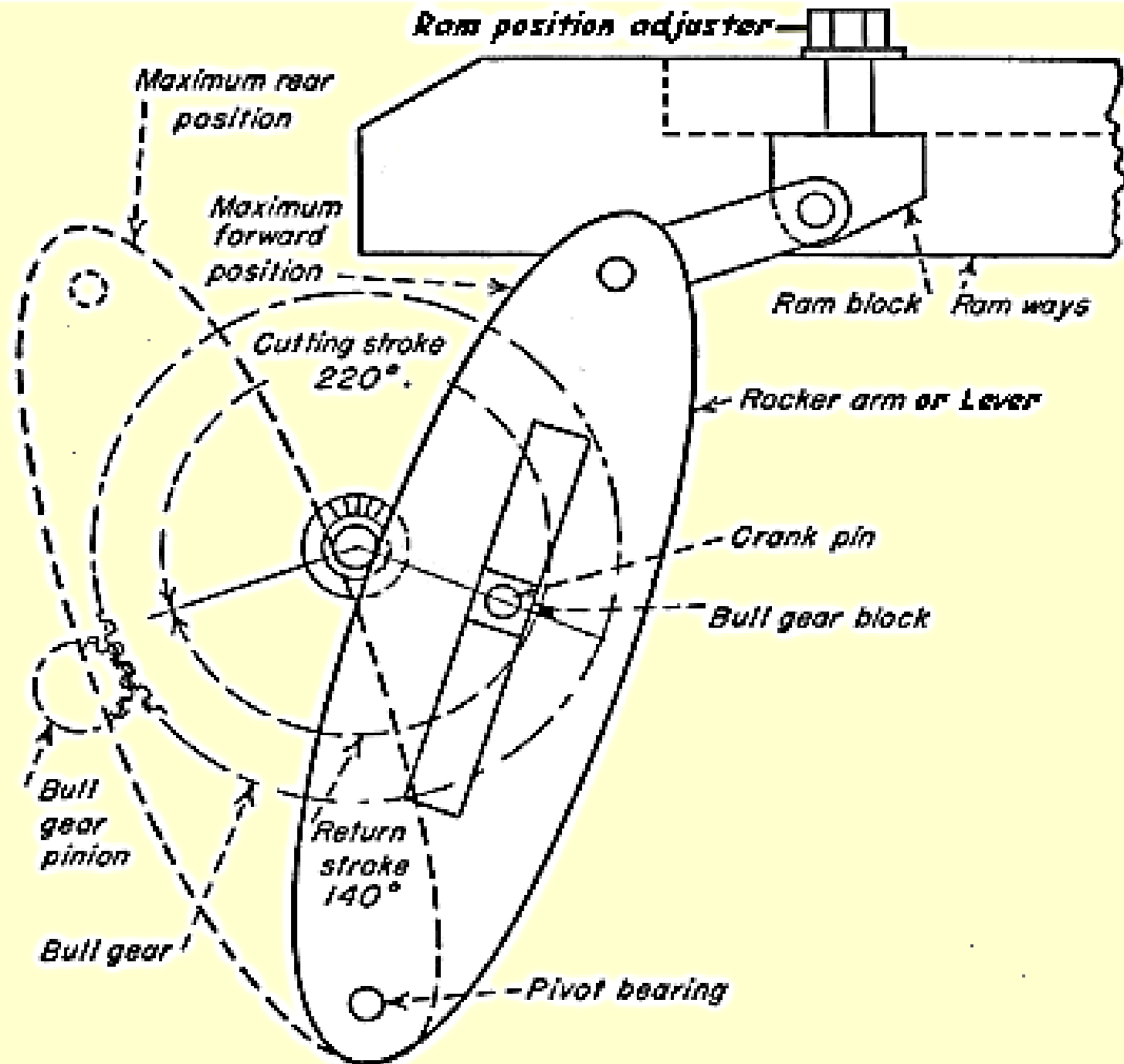

QUICK RETURN MOTION

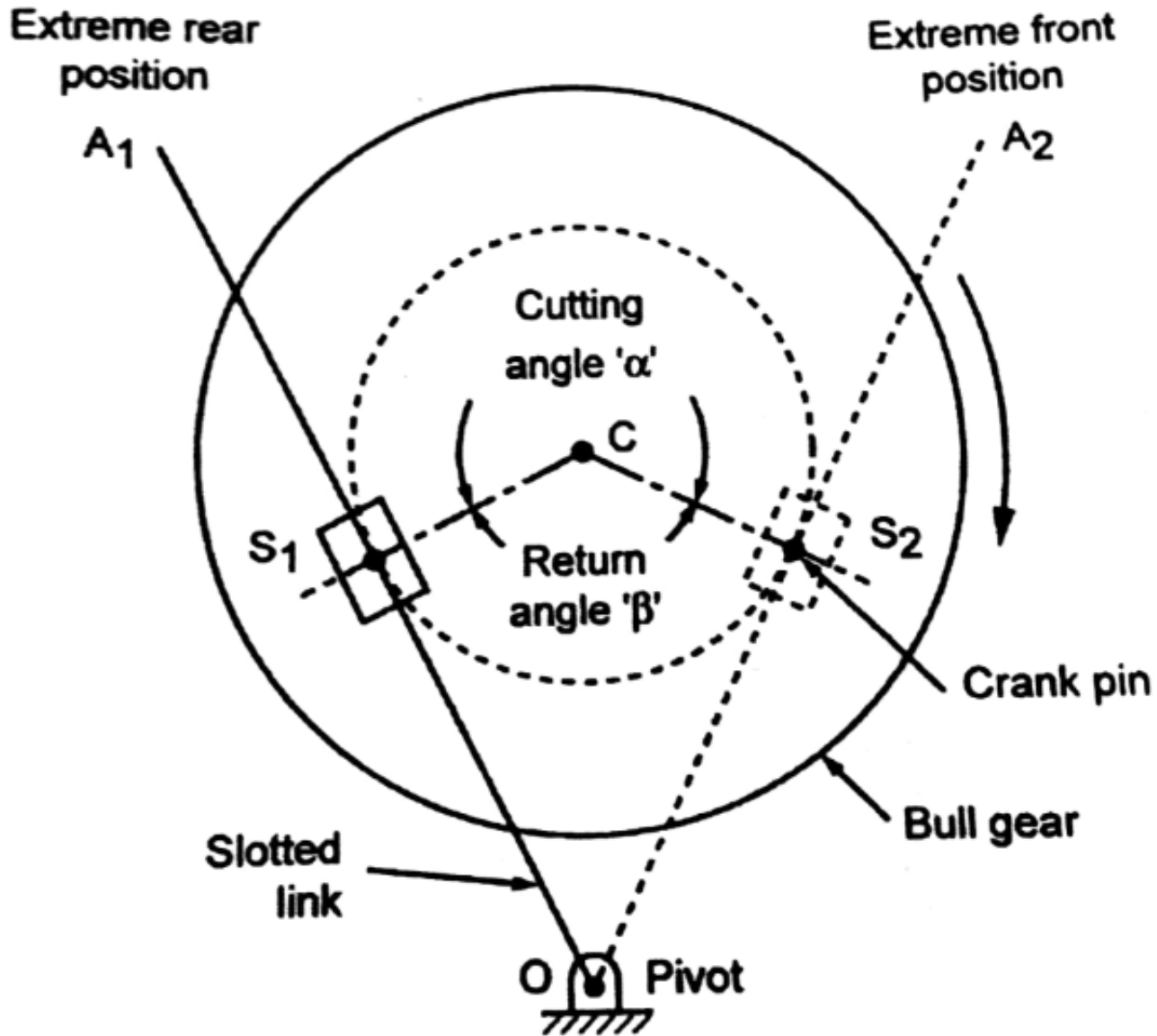

HYDRAULIC MECHANISM

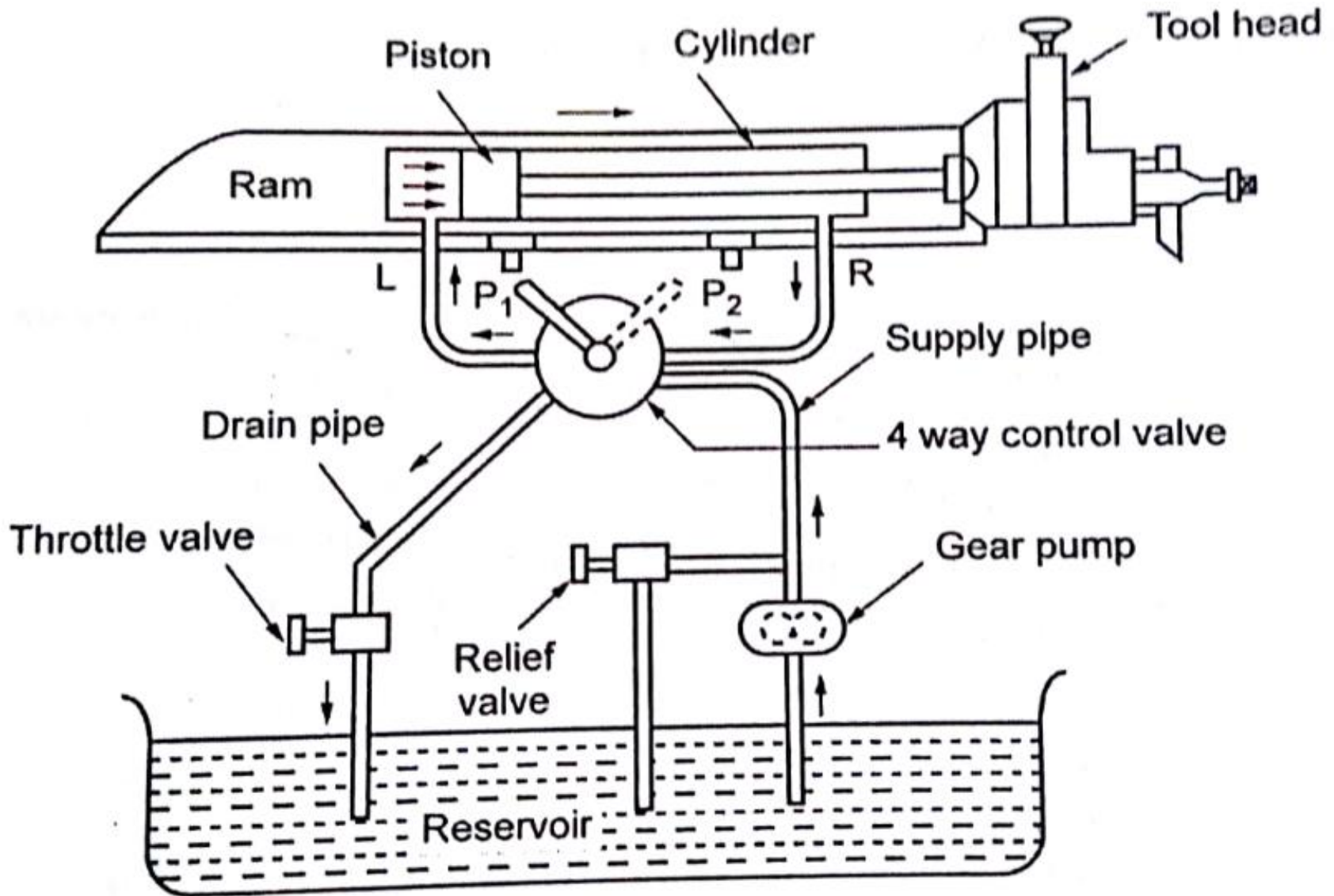

Hydraulic drive

WHITWORTH QUICK RETURN MECHANISM

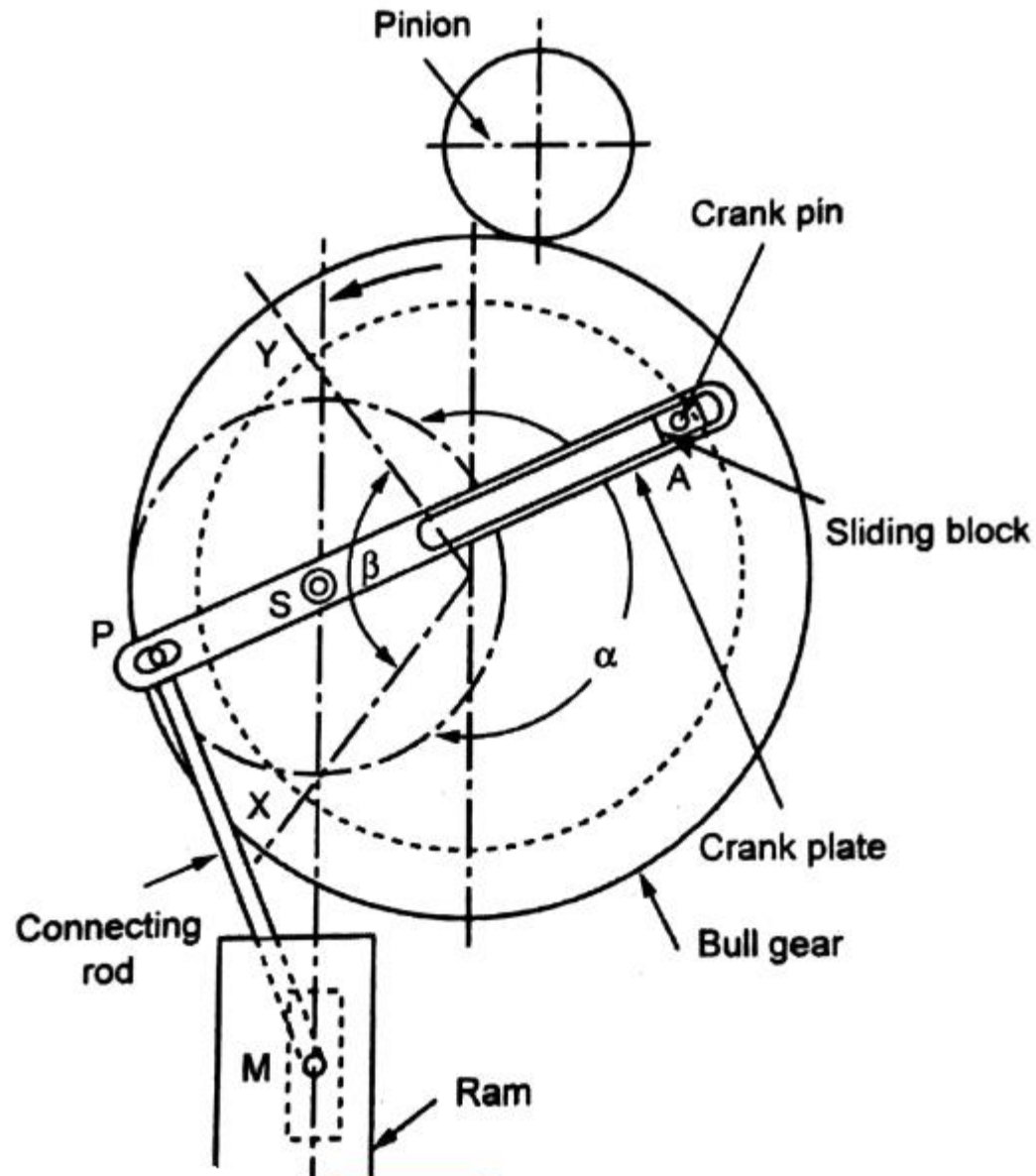

WORK HOLDING DEVICES FOR SHAPING MACHINES

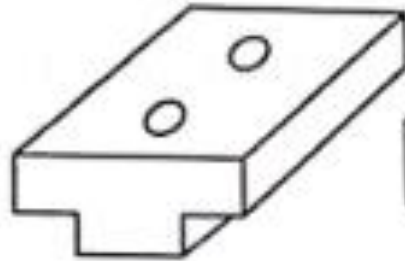

Strip

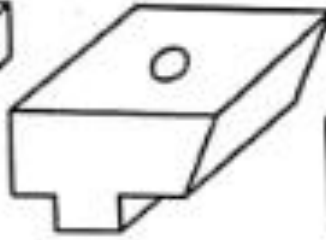

Wedge strip

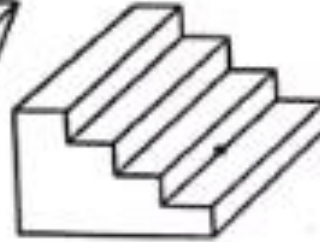

Step block

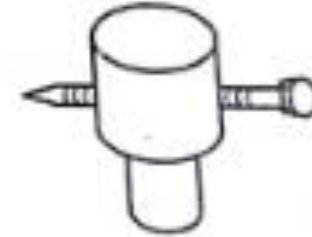

Stop pin



Hold down



Toe dog

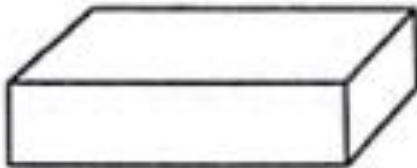

Parallel



Clamp



U-Clamp

Clamping devices

CLAMP IN A VICE

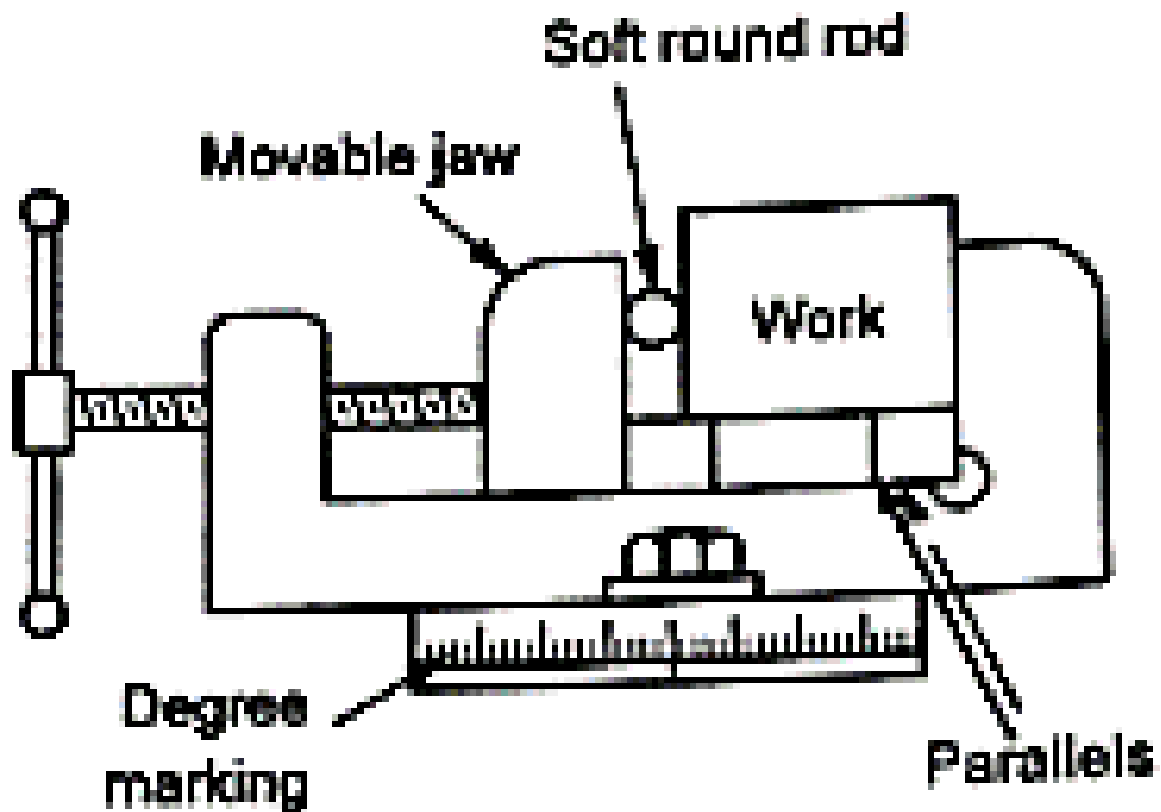

Swivel base machine vice

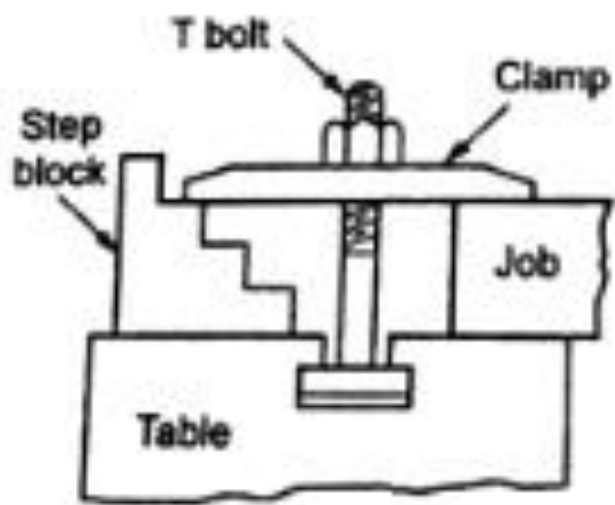

(a) T bolt and clamp

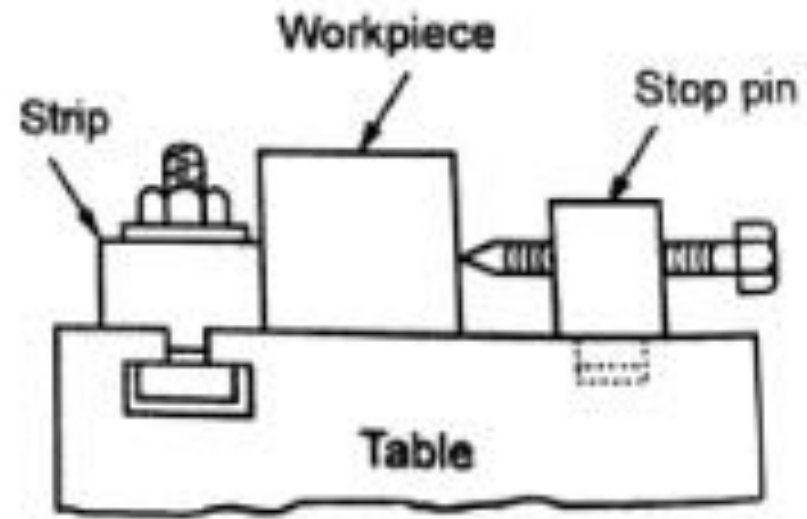

(b) Strip and stop pin

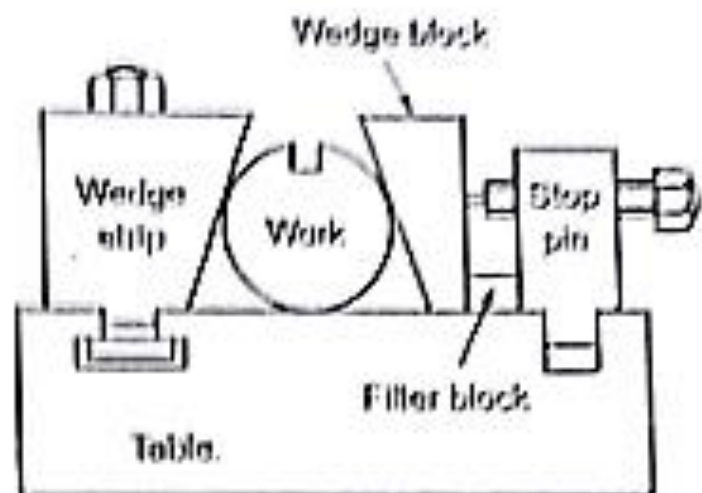

(c) Wedge strip and stop pin

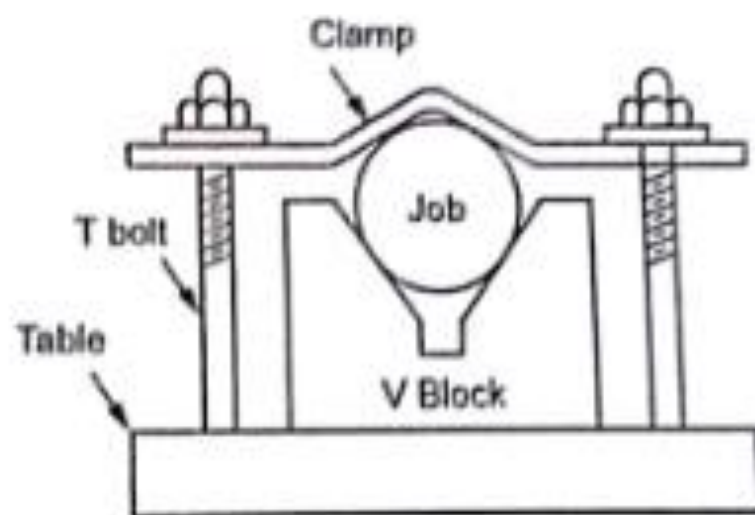

V-block

Operations Performed in Shaping Machine

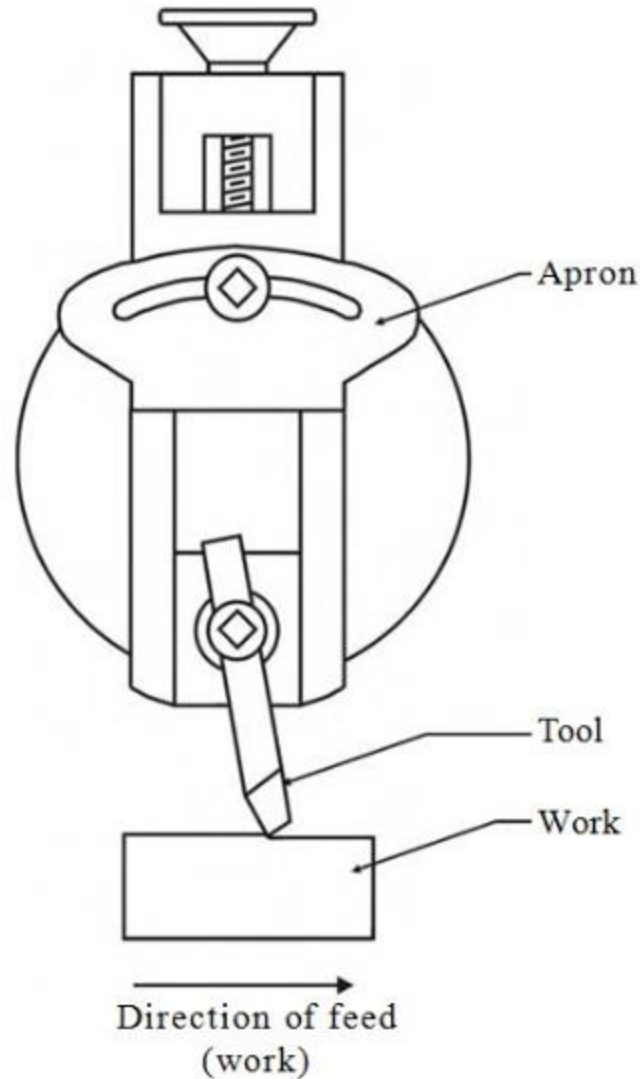

Machining a Horizontal Surface

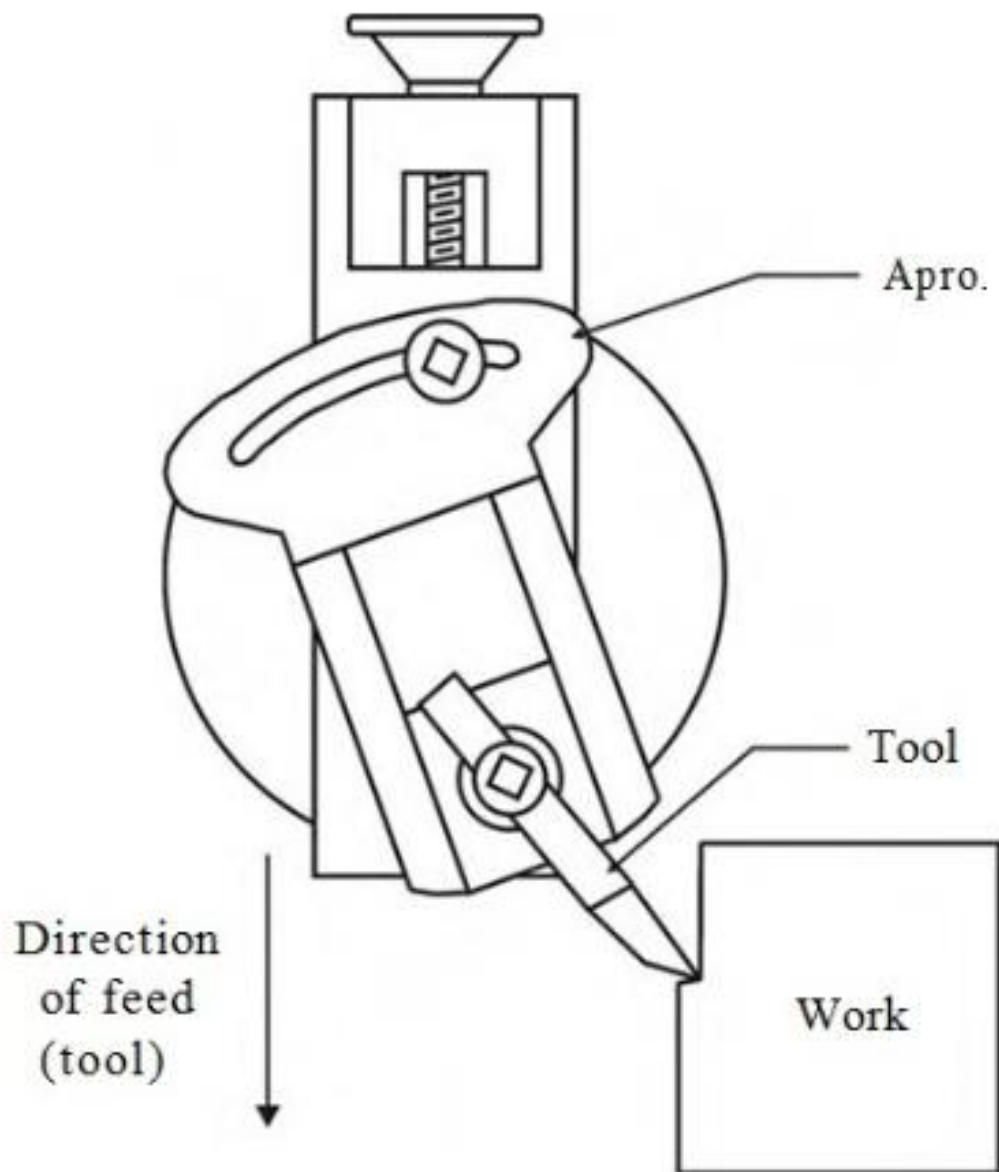

Machining a Vertical Surface

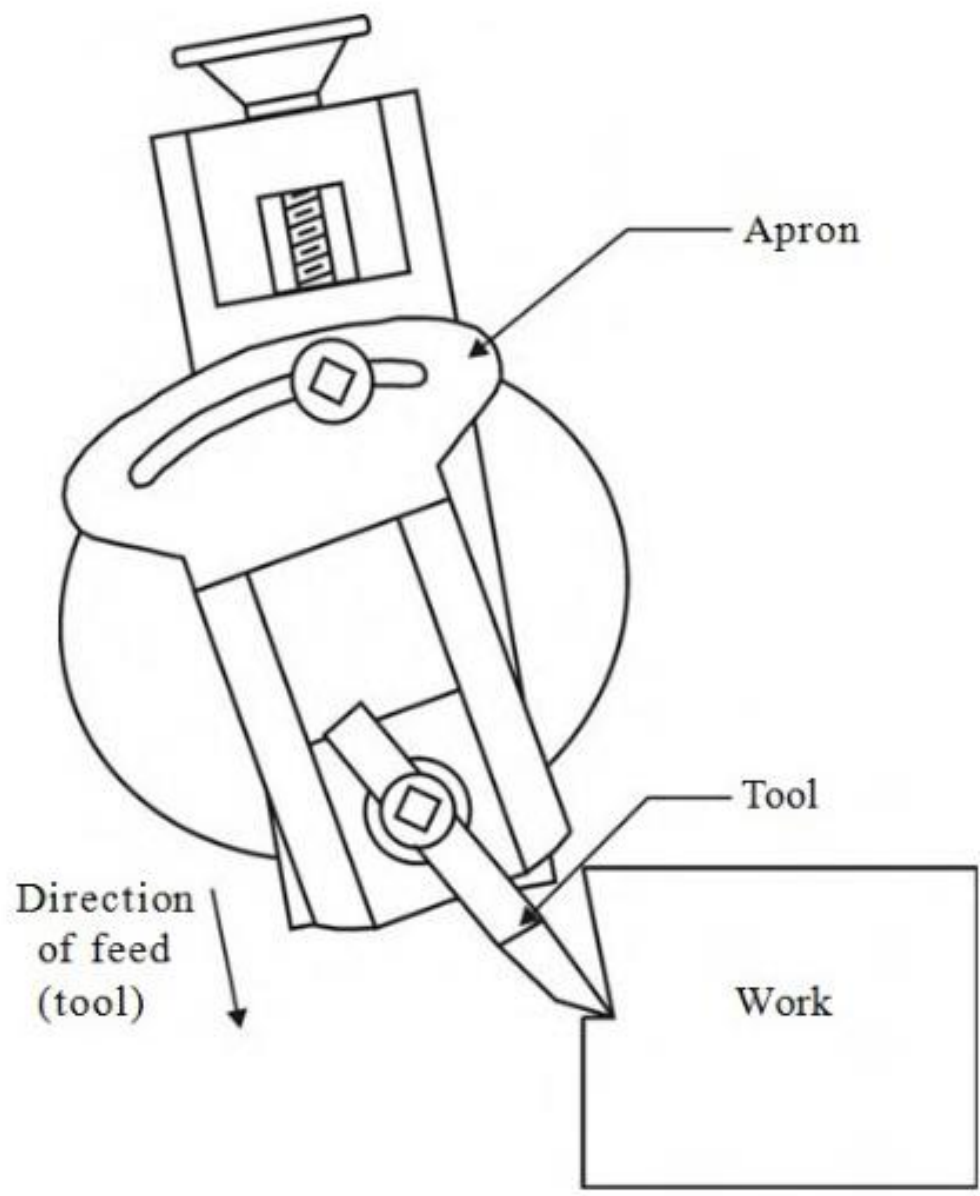

Machining a Angular Surface

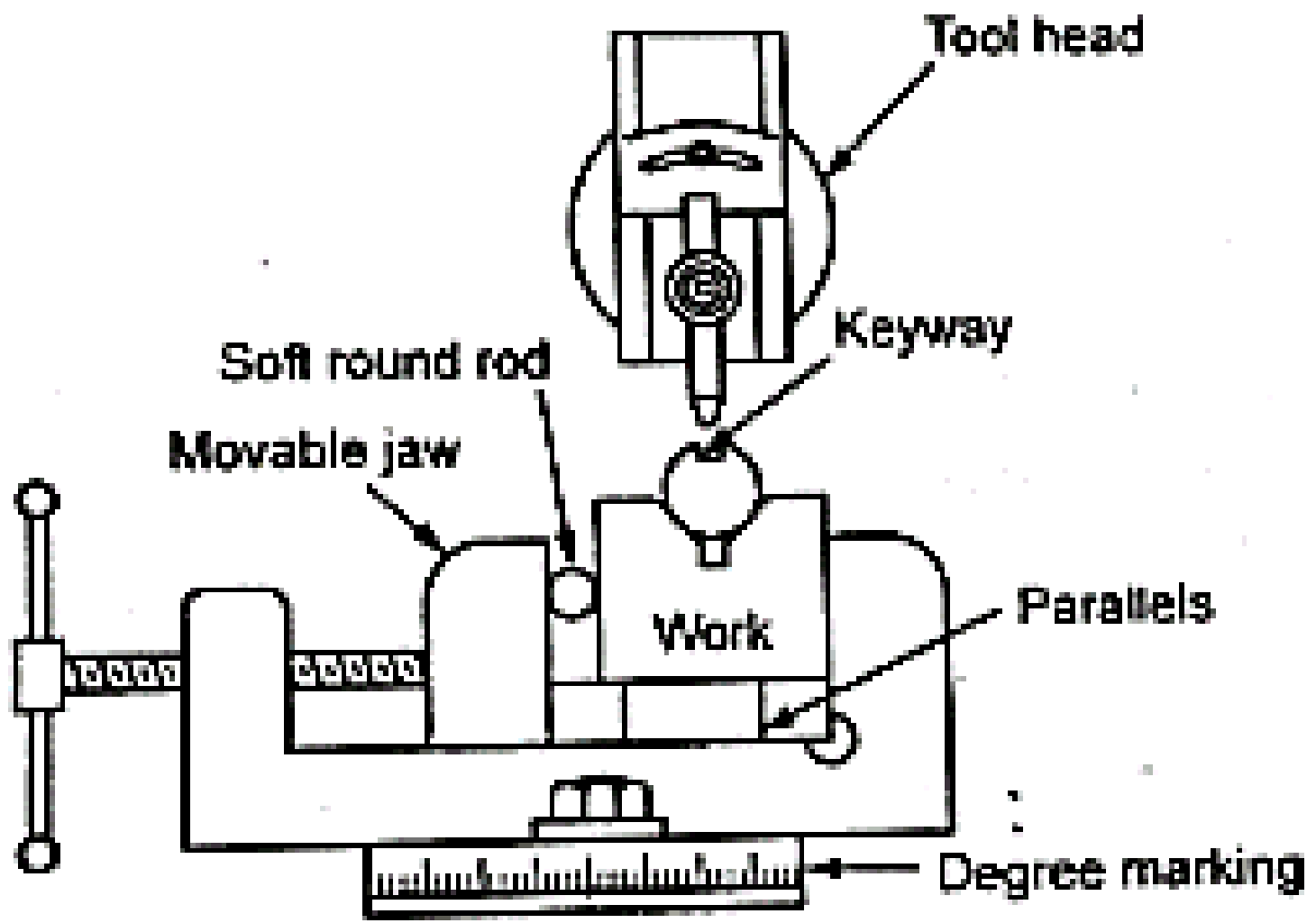

Machining grooves and slots

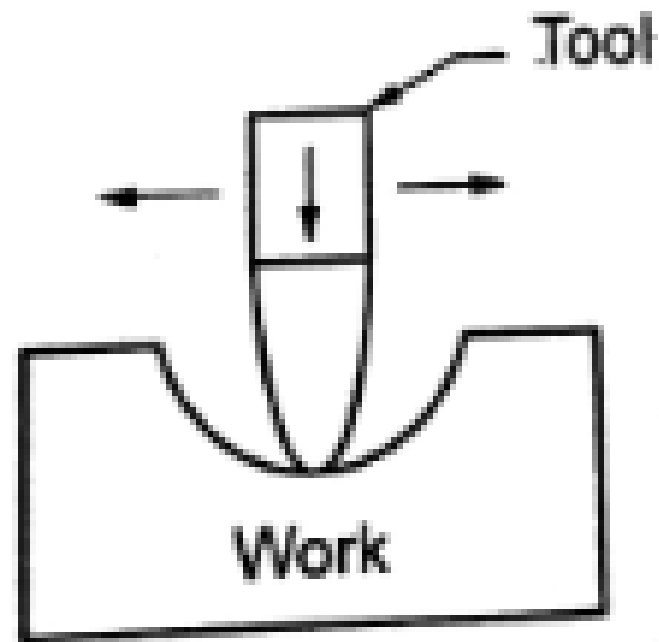

Machining irregular surface

SPECIAL OPERATIONS PERFORMED BY SHAPER

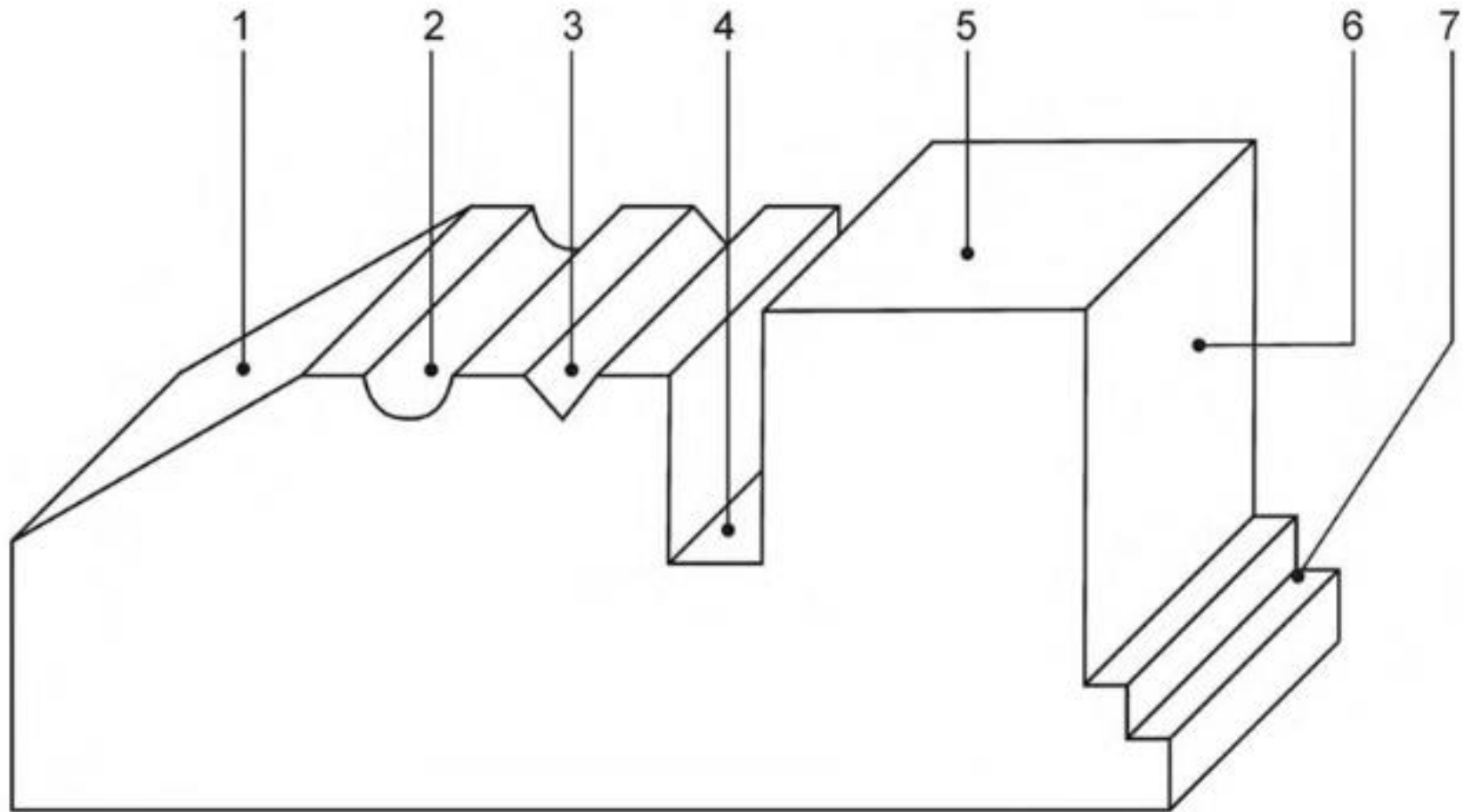

Various Shaper Operations

1. Inclined surface 2. Concave surface 3. 'V' groove 4. Deep slot 5. Horizontal surface
6. Vertical surface 7. Step cut surface

Machining Time

From the cutting speed, we can find that the time required to complete one double stroke is given by

$$t = \frac{L(1 + m)}{1000v} \text{ min} \quad (7.3)$$

With a feed of f mm/double stroke, number of double strokes required to machine a surface of width w will be

$$N_s = \frac{w}{f} \quad (7.4)$$

Hence, total time for machining the surface will be

$$t = \frac{Lw(1 + m)}{1000vf} \text{ min} \quad (7.5)$$

or,

In terms of ram strokes N , the time for machining surface is given by

$$t_s = \frac{w}{fN} \text{ min} \quad (7.6)$$

Material removal rate

$$MRR = fdNL(1 + m) \text{ mm}^3/\text{min} \quad (7.7)$$

where d is depth of cut in mm, f in mm/stroke, N in strokes/min, and L is length of stroke in mm.

The Planer

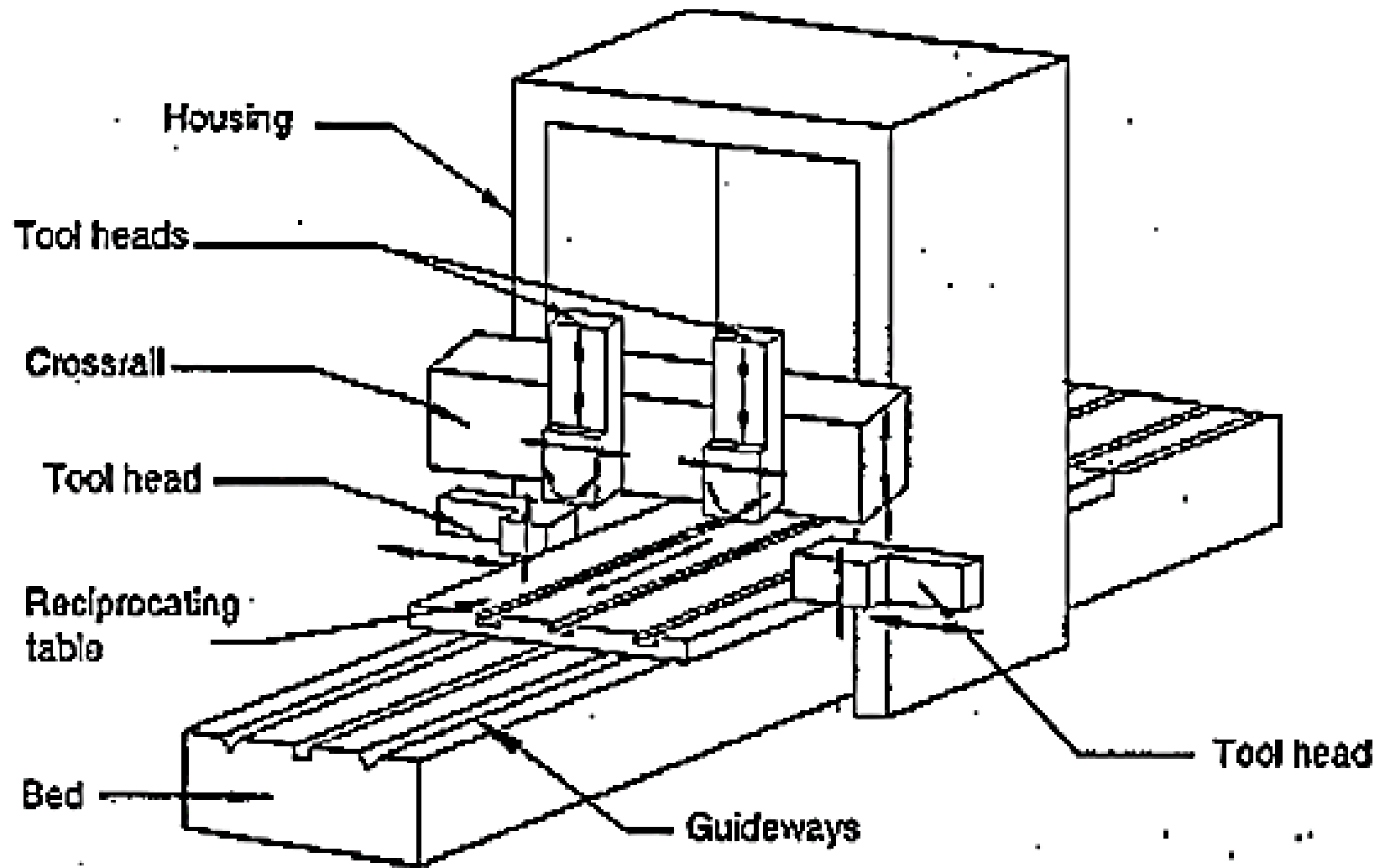

A double housing planer.

The Planer

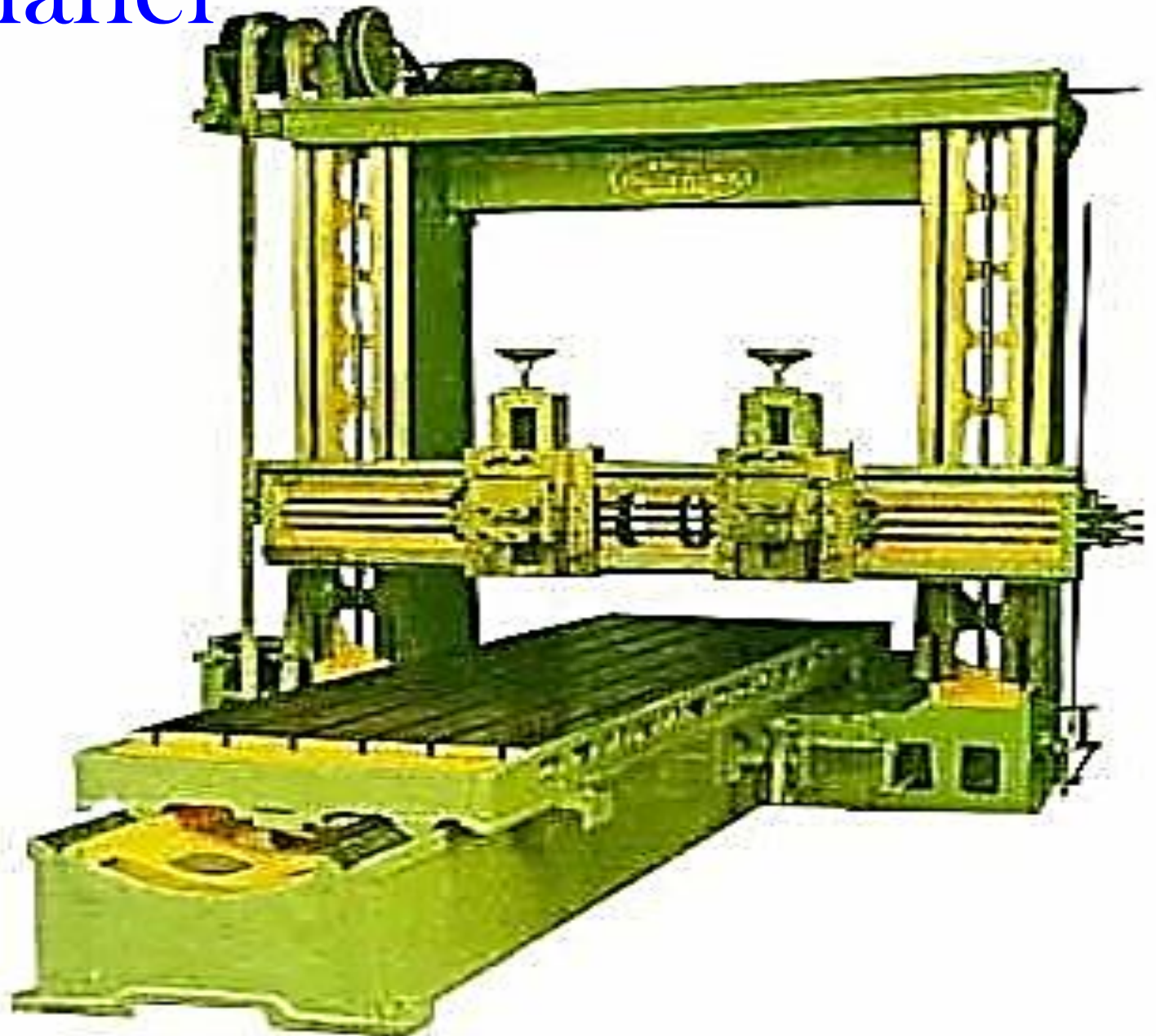

PLANER



Planer

- Planer or planing machine is a machine tool, which like the shaper produces flat surfaces in horizontal, vertical or inclined plane.
- Fundamental difference is that the planer operates with an action opposite to that of the shapers, i.e., the work piece reciprocates past one or more stationary single point cutting tools.
- Planers are meant for machining large sized work pieces, which cannot be machined by the shaping machines.

Types of Planing Machines

- Double housing planer
- Open side planer
- Pit planer
- Edge planer
- Divided head planer

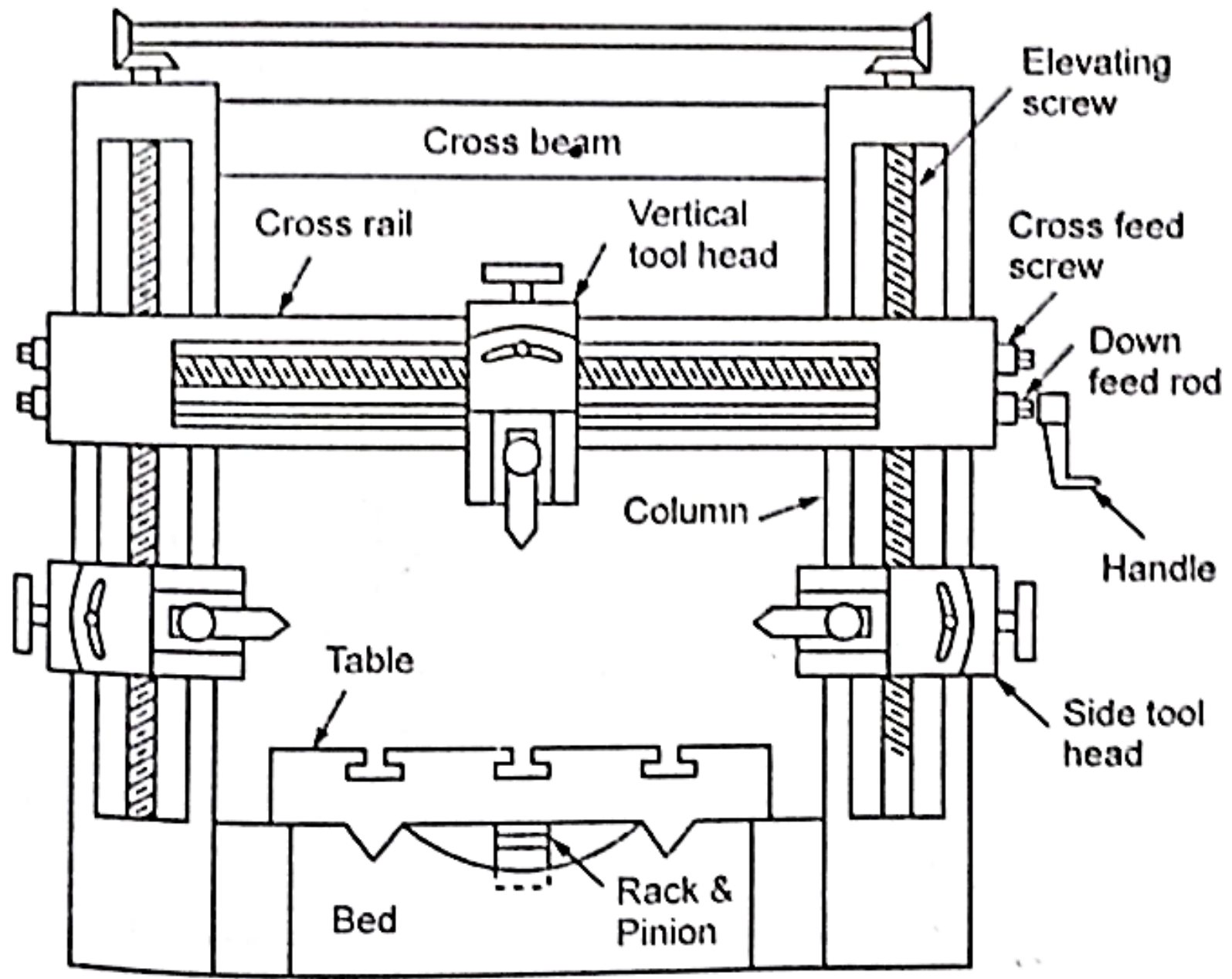

Double-housing planer

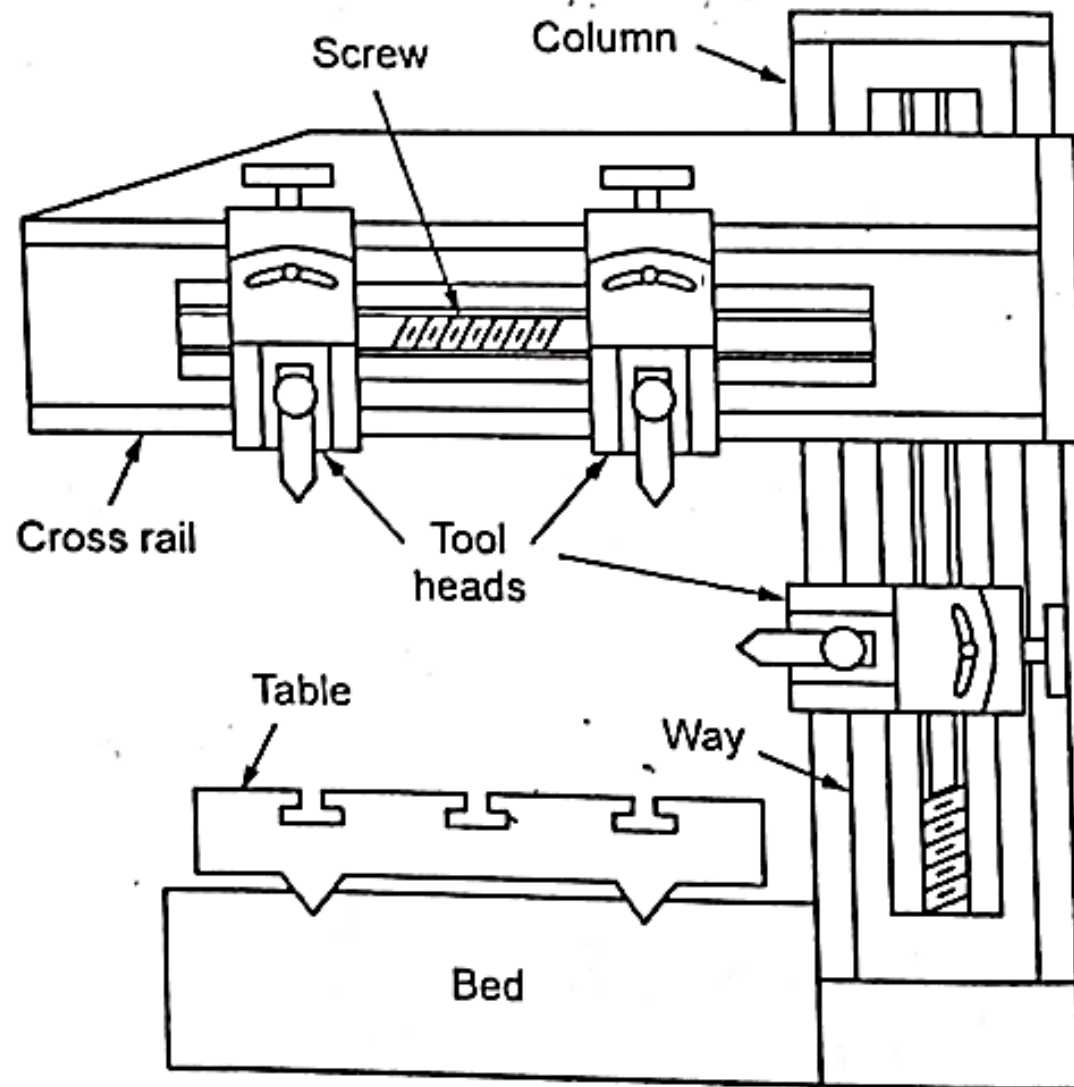

Open side planer

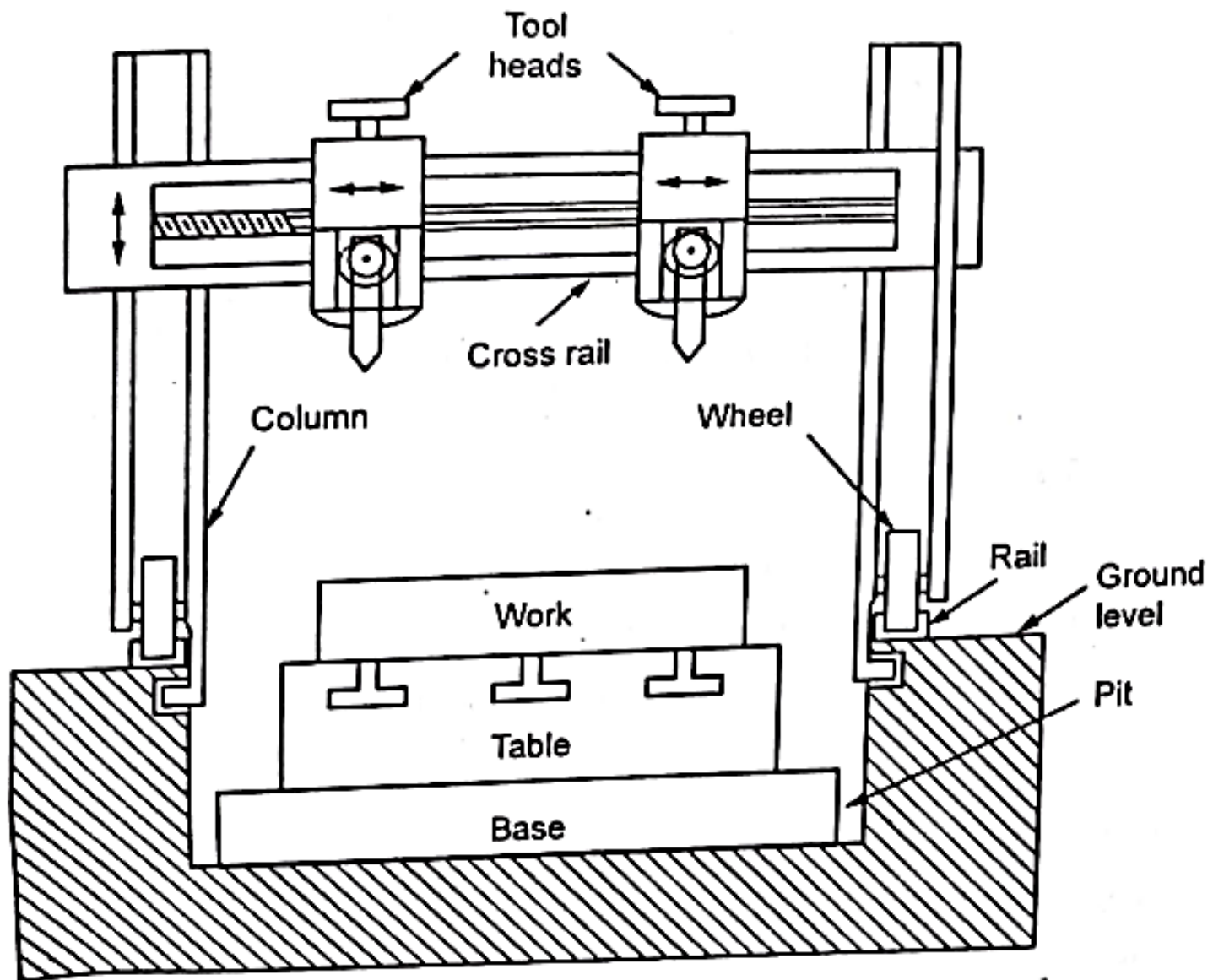

Pit planer

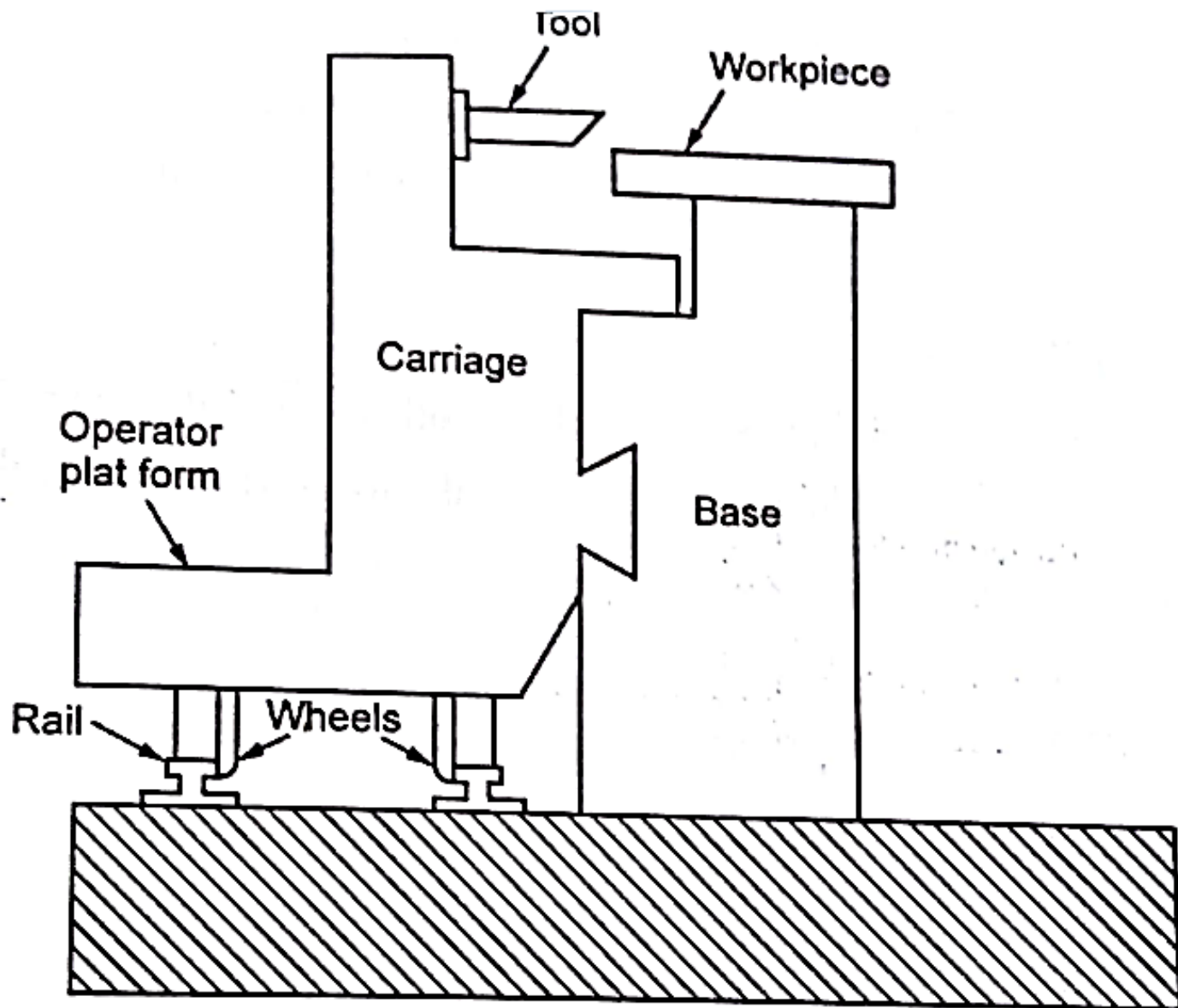

Edge planer

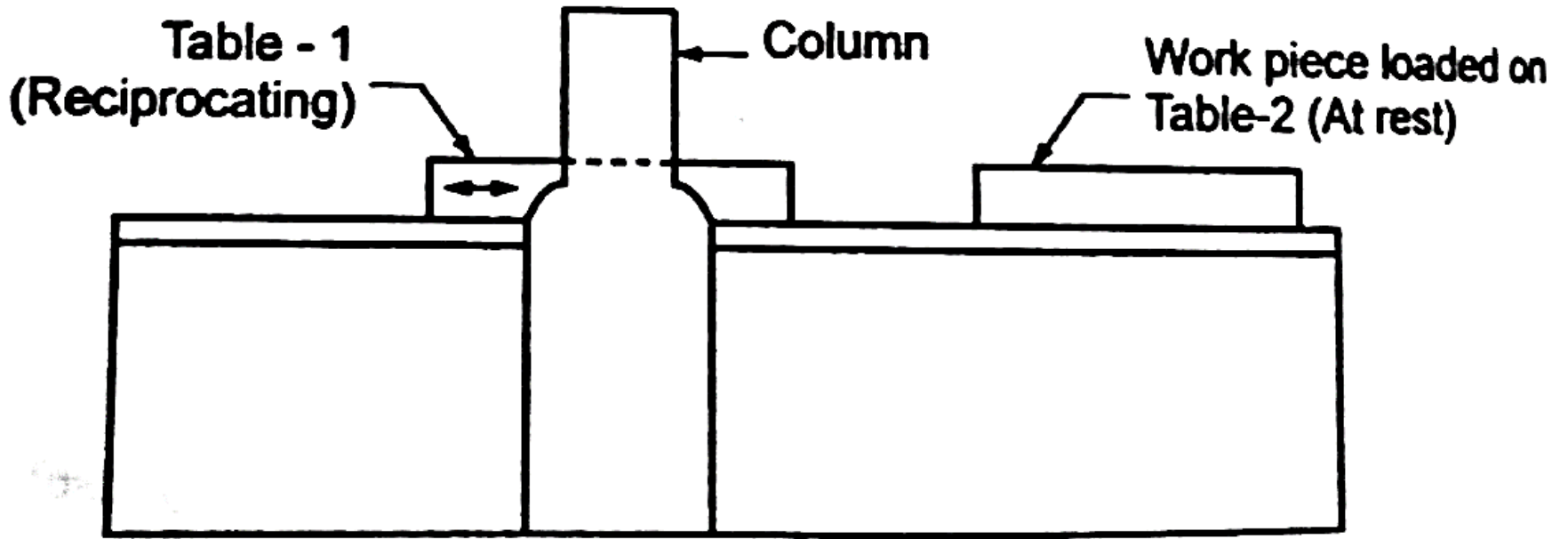

Divided head planer

Size or Specifications of a planing machine

1. Distance between two columns
2. Stroke length of the planer
3. Radial distance between the top of the table and the bottom most position of the cross rail
4. Maximum length of the table
5. Power of the motor
6. Range of speeds and feed available
7. Types of drives required

WORK HOLDING DEVICES IN PLANING MACHINES

Following clamping devices are used

- Angle plate
- Planer jacks
- Stop block
- Adjustable screw stop

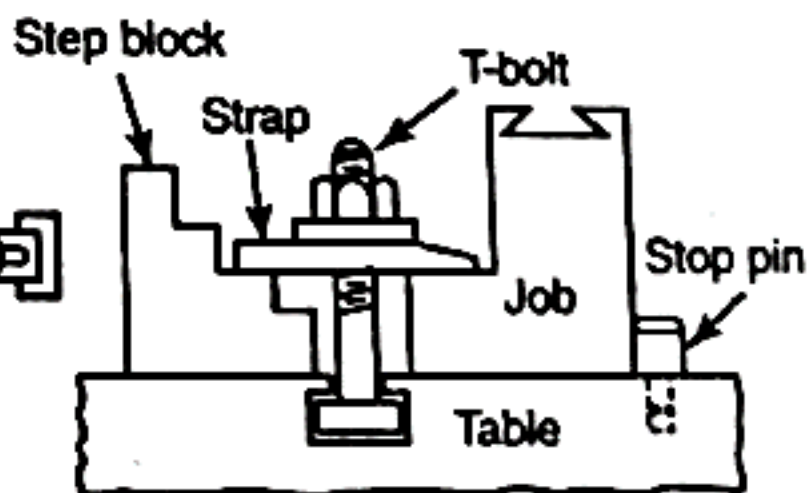
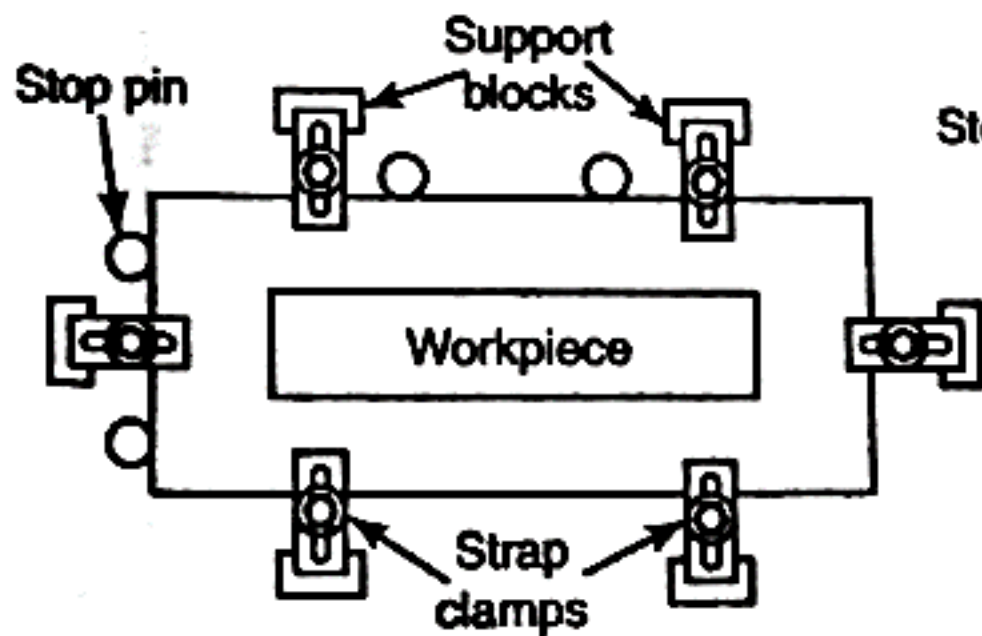
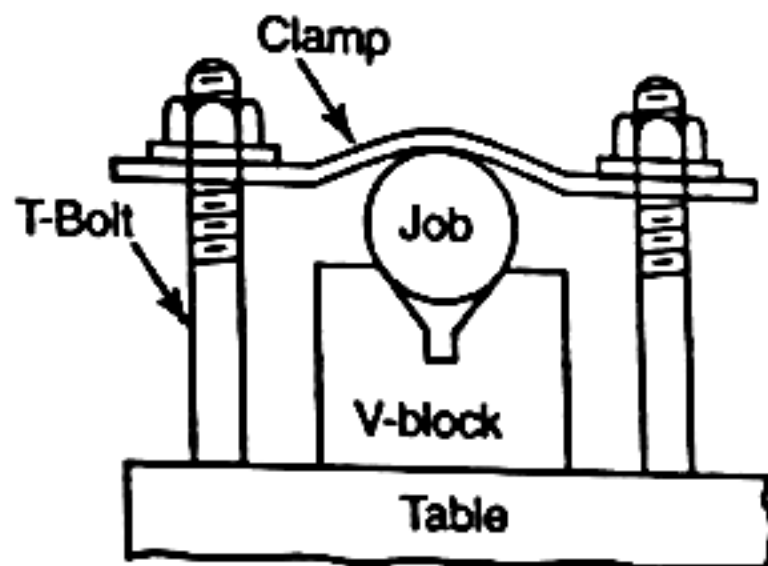
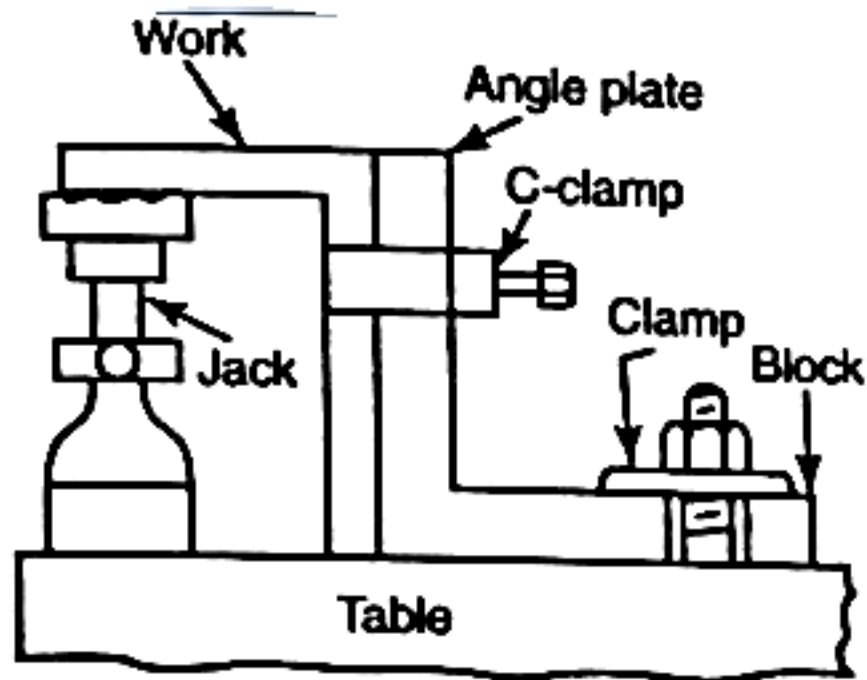

PLANING FIXTURES

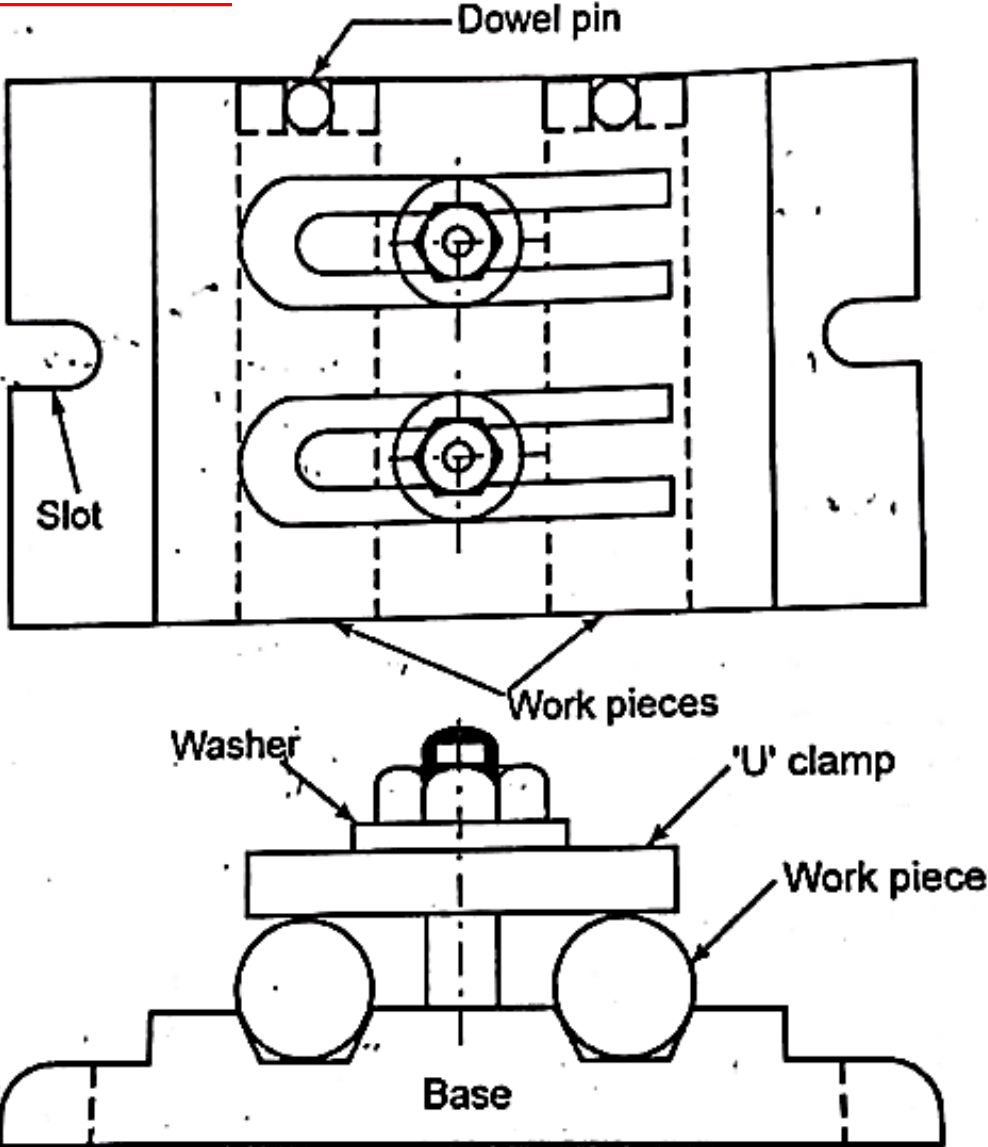

Planing fixtures :

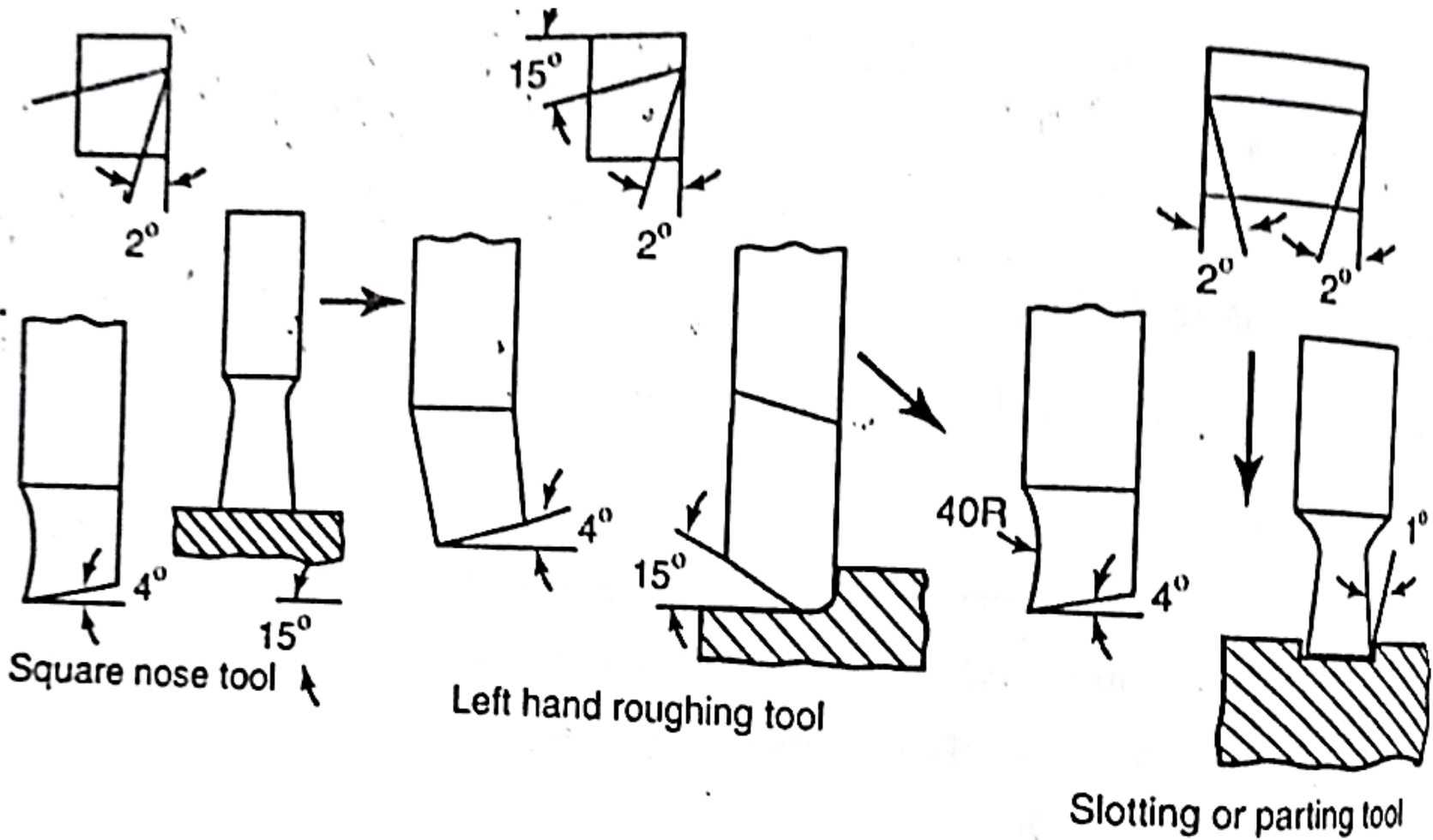

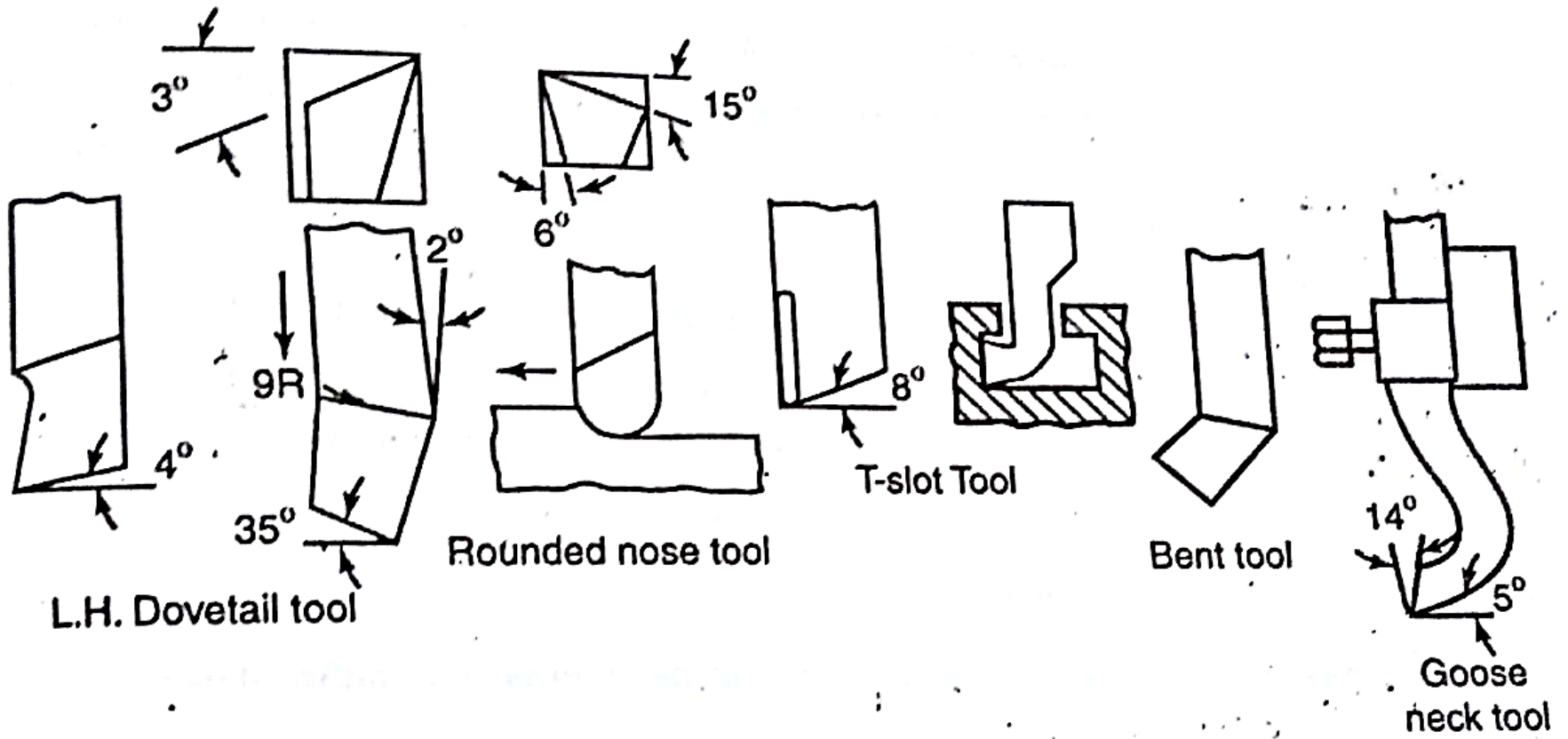

OPERATIONS PERFORMED ON PLANING MACHINES

- Planing horizontal surface
- Planing of an angle
- Planing vertical surface
- Planing curved surface

PLANING CURVED SURFACES

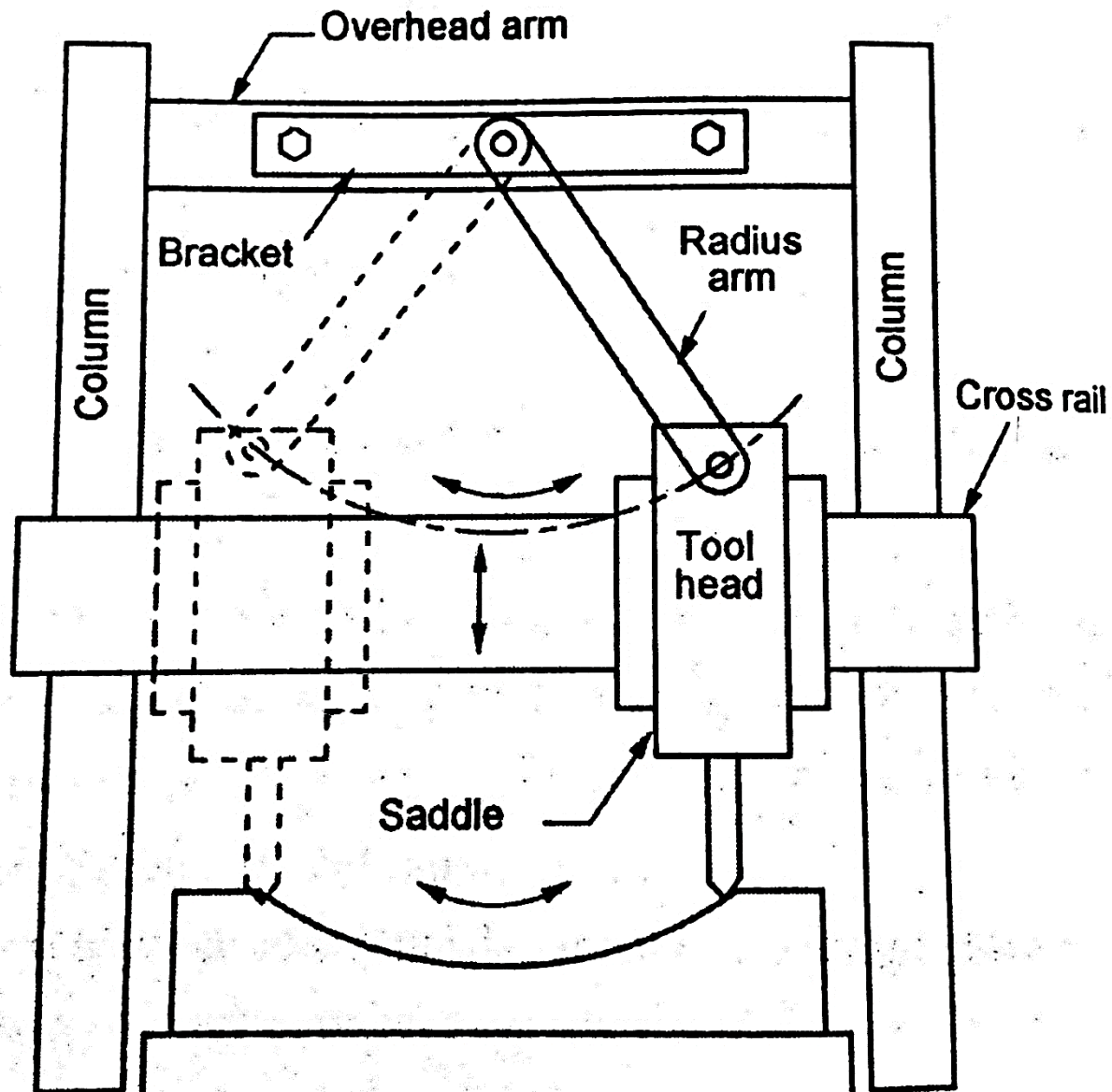

OPEN AND CROSS BELT DRIVE

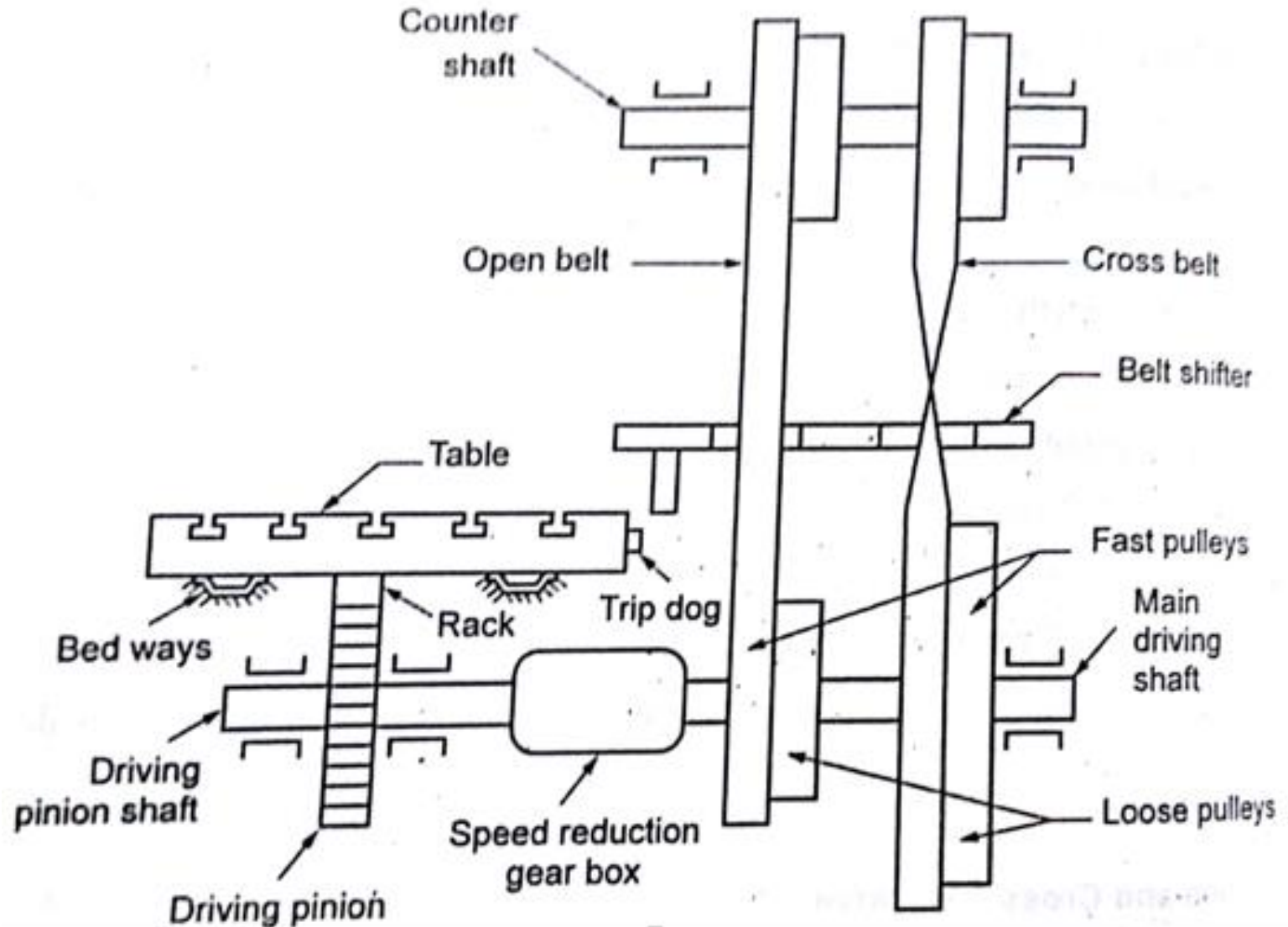

ELECTRIC DRIVE

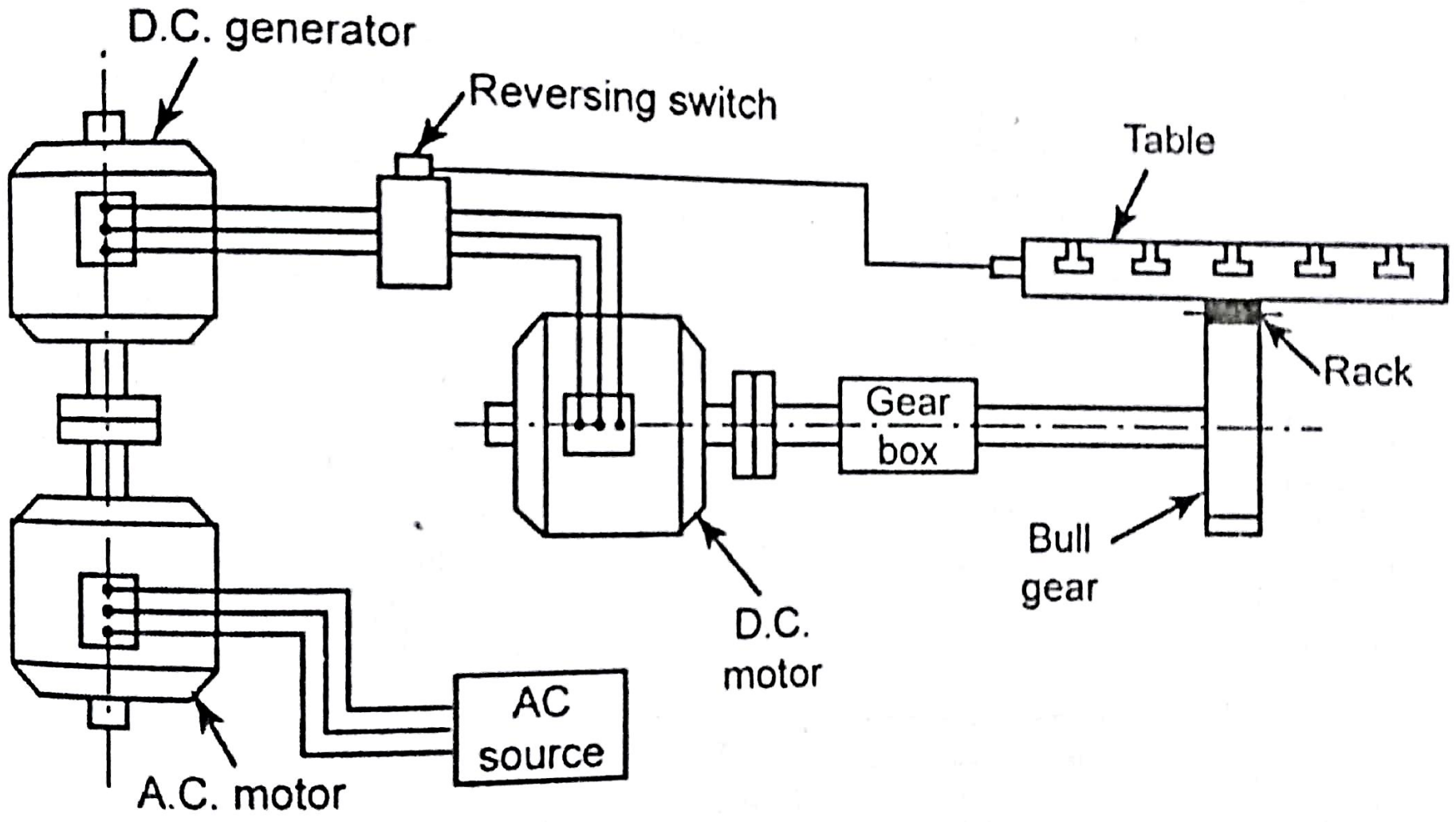

AUTOMATIC FEED MECHANISM

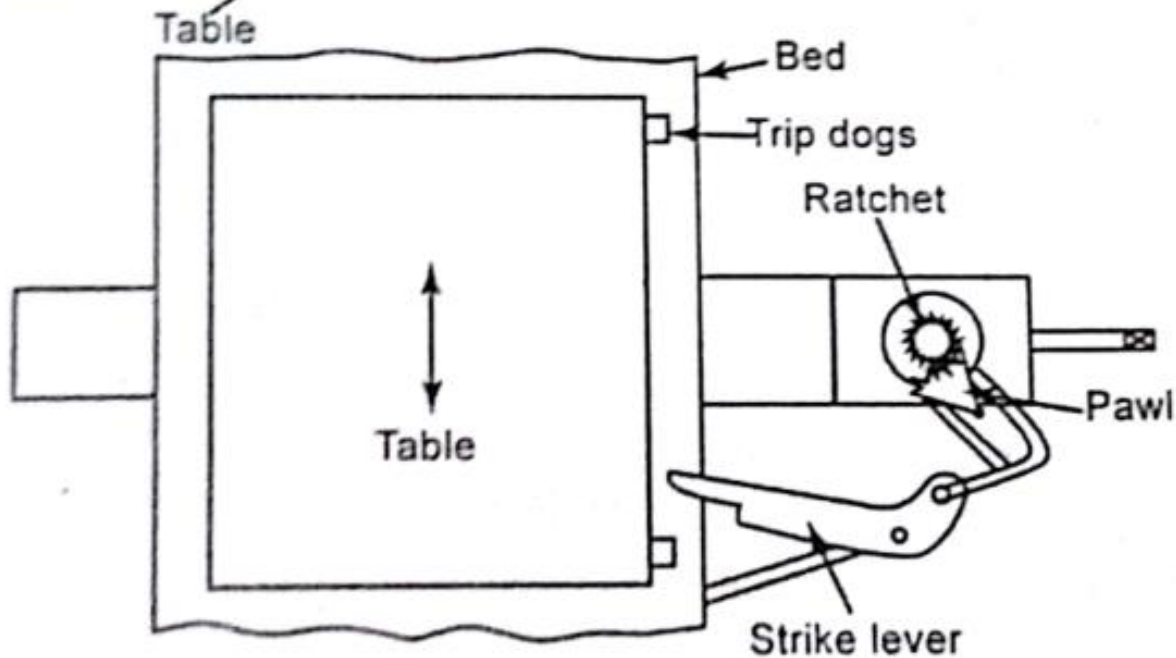
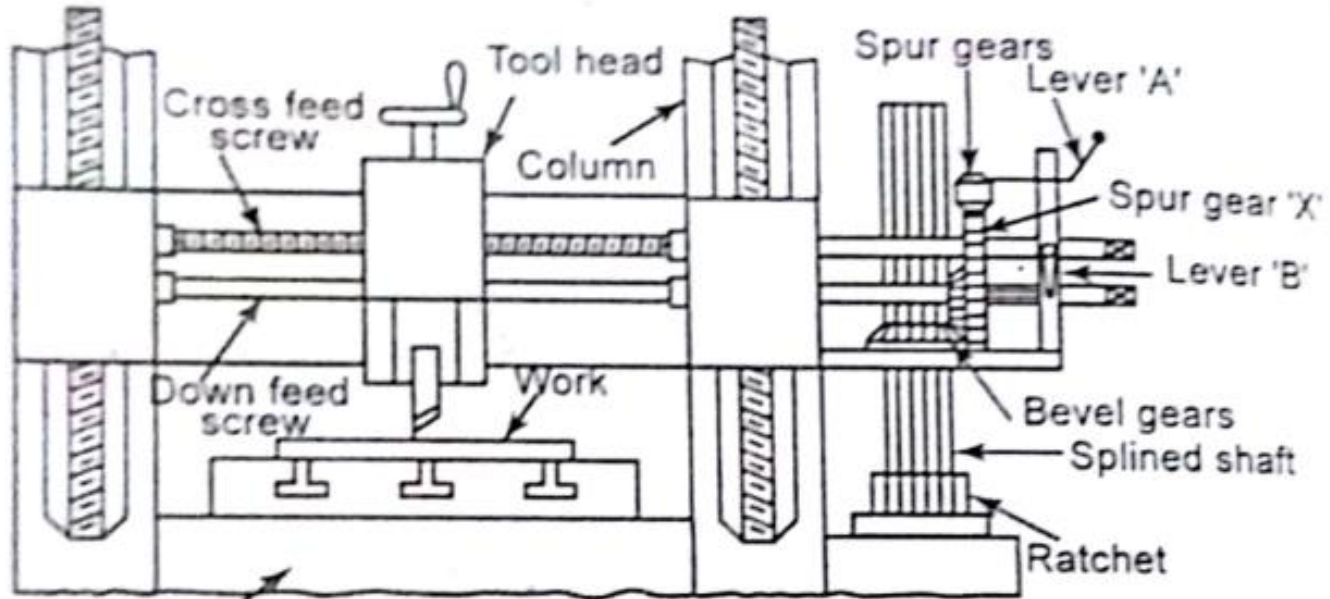

Size of shaper and planers

- The size of planer and shaper are specified by the maximum length of stroke.
- The normal maximum stroke length of the stroke is 800mm.

PLANER v/s SHAPER

<i>S. No.</i>	<i>Planing machine</i>	<i>Shaping machine</i>
1.	Tool is stationary and work reciprocates.	Tool reciprocates and the work is stationary.
2.	This machine is used for machining large and heavy workpieces.	This machine is used for machining medium and small workpieces.
3.	It gives more accuracy as the tool is rigidly supported during cutting.	Less accuracy due to the overhanging of ram.
4.	Production time is more since it has single tool head.	Production time is less since it has two or four tool heads.
5.	Work setting requires more skill.	Work setting is easier.
6.	Heavy cut can be given as it has rigid base and uses strong tools.	Heavy cut cannot be given.

Slotting machine (SLOTTER)

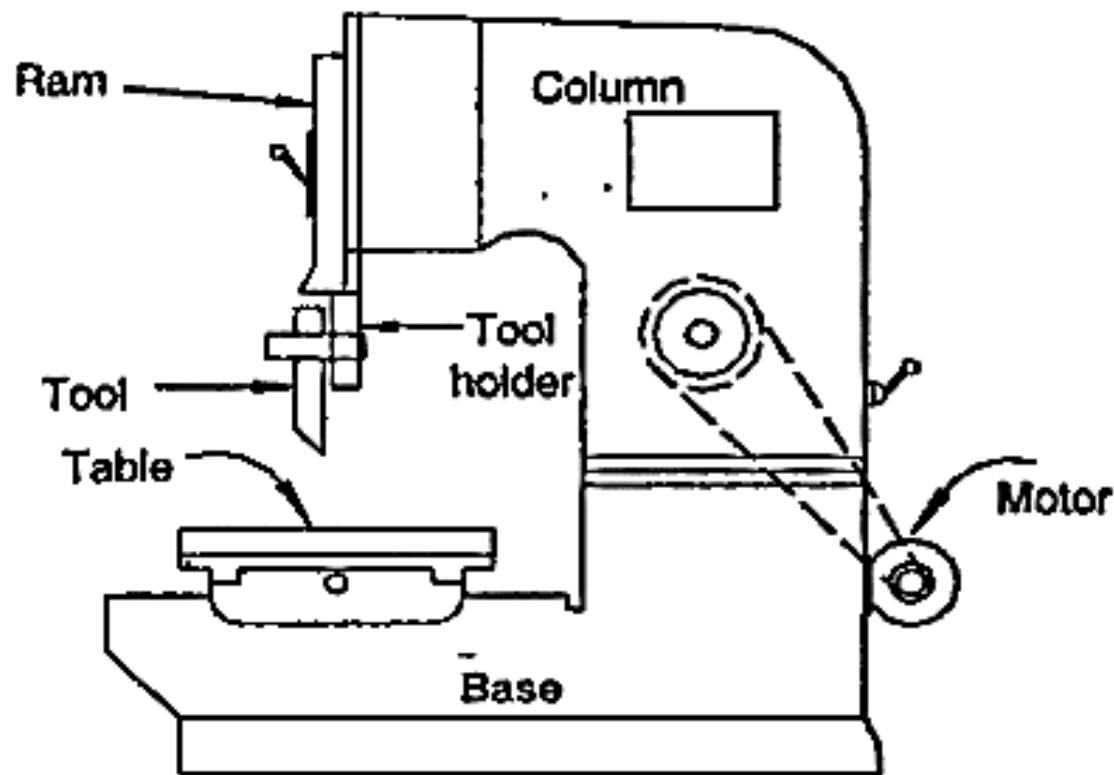

(a) Slotting machine

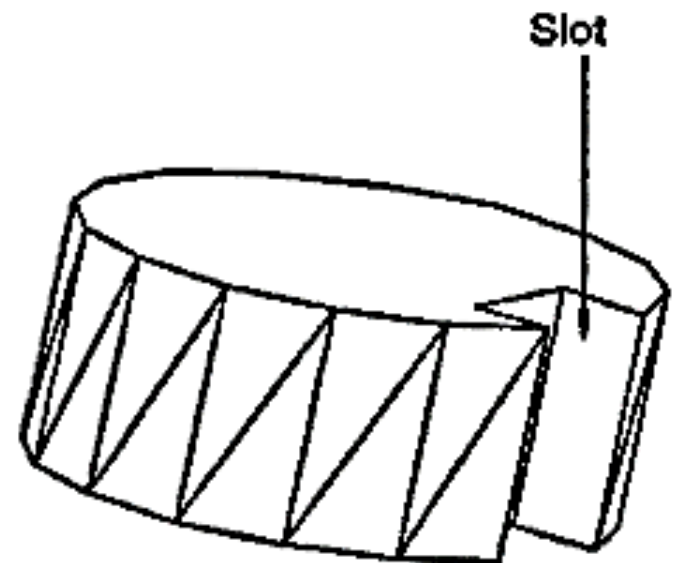

(b) Slot produced by slotting machine

Slotting machine and a slot produced by slotting machine.

Slotting Machine



- *Basically slotting machine is a vertical axis shaper*
- *The tool moves vertically rather than in a horizontal direction*
- *It has a vertical ram and a hand or power operated rotary table*
- *The stroke of ram is smaller in slotting machines than in shapers*

Main parts of a slotter

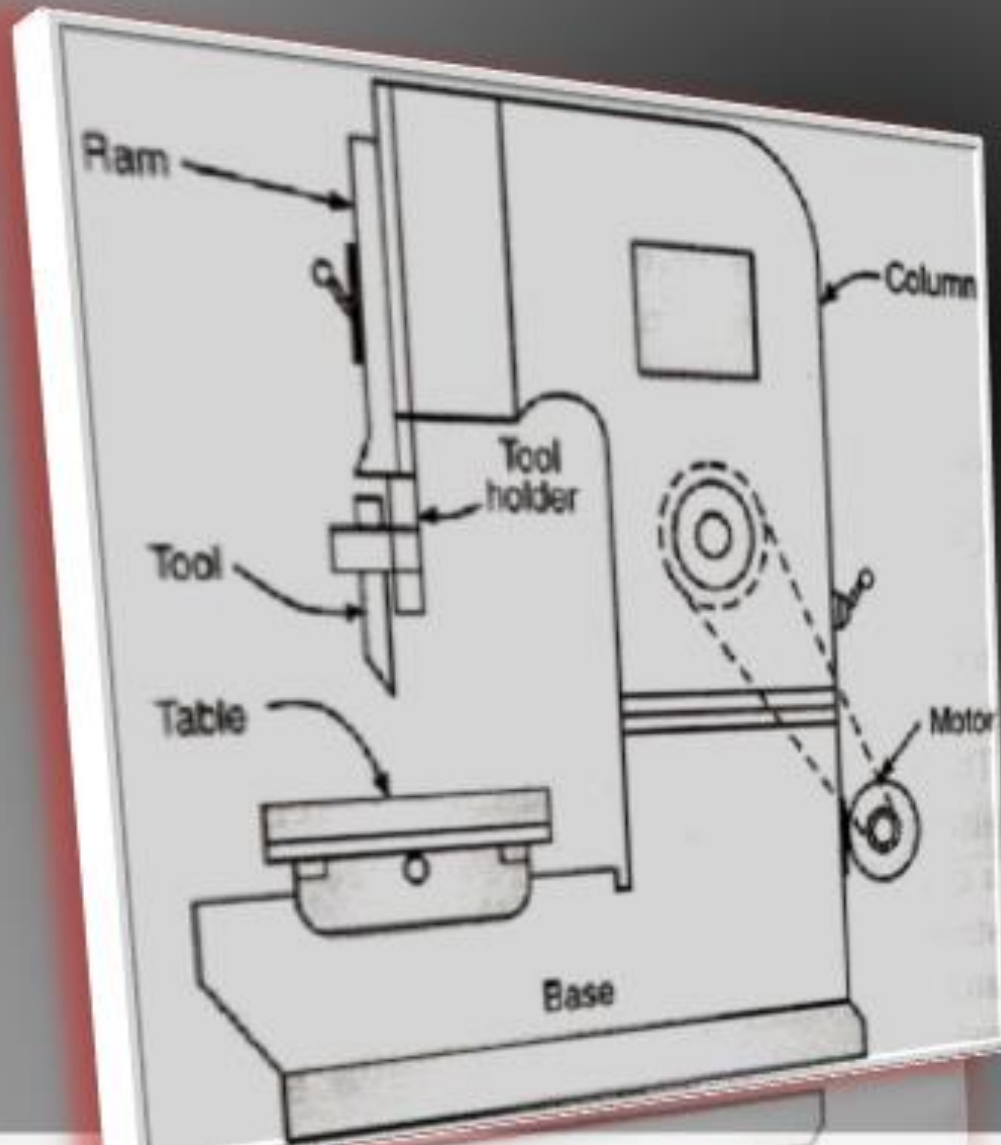

- *Base*
- *Column*
- *Table*
- *Ram*

➤ **Base:** It is also known as bed and it is a heavy cast iron construction

It acts as a support for the column, the driving mechanism of ram, table and other fittings

➤ **Column:** It is made of cast iron & it acts as a housing for the complete driving mechanism

➤ **Table:** usually a circular table is provided in slotter.

➤ T-slots are provided on top of the table to clamp the work

➤ **Ram:** it moves in vertical direction between the vertical guideways provided in front of the column

➤ The ram supports the tool head to which the tool is attached & the cutting action takes place during the downward movement of the ram

Size and Specification

The complete specification of a typical **300 mm stroke slotter** are as follows

○Stroke maximum	=300 mm
○Stroke minimum	=0 mm
○Height between table and head	=450mm
Maximum diameter accommodated when machining at centre	=900 mm
○Diameter of the table	=500 mm
○Traverse of the table , longitudinal	=450 mm
○Traverse of the table, transverse	=350 mm
○Height overall	=2000 mm
○Length of bed	=1375 mm
○Width of bed	=412 mm
○Height of bed	=575 mm
○Height of head	=1275 mm
○Belt size	=75 mm
○H.P required	=2 H.P

Slotted drive mechanisms

- Slotted disc mechanisms*
- Variable speed reversible motor drive*
- Hydraulic drive*
- Slotted link drive*

Types of Slotter

- **Puncher slotter**
- **General production slotters**
- **Precision tool room slotters**
- **Key seater**



ROUGHING TOOL

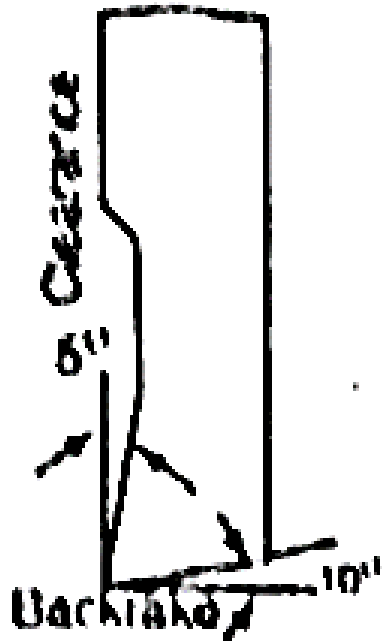

SLOTTING TOOL

SQUARE NOSE TOOL

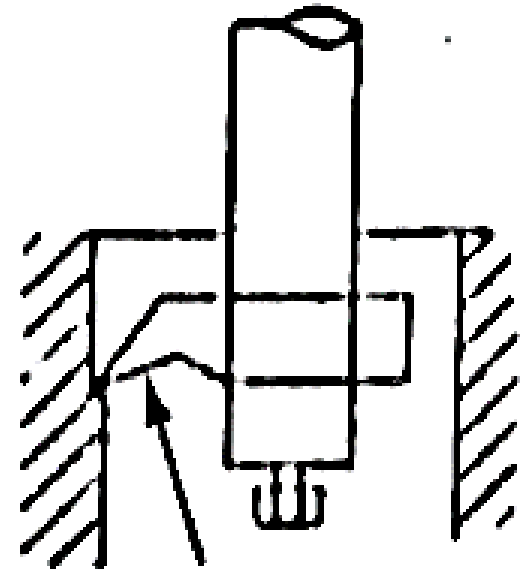
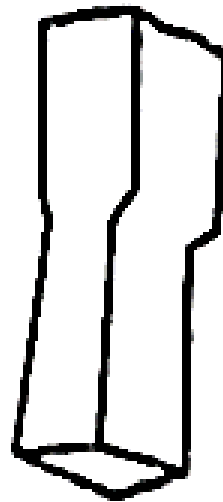
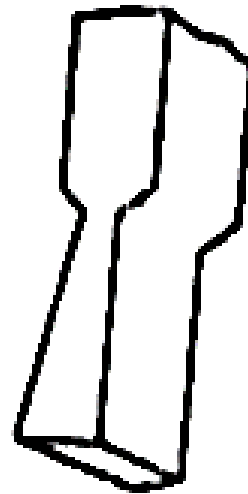

TOOL DIT

Type of tools

Work holding devices

1. **Clamps**
2. **T-bolts**
3. **Vice**
4. **Parallel strips**
5. **Special fixtures for holding work**

Special fixtures for holding work

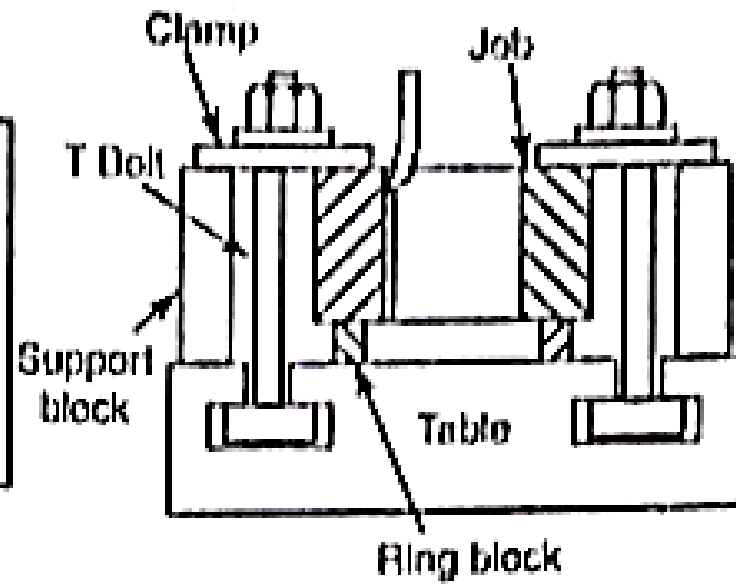
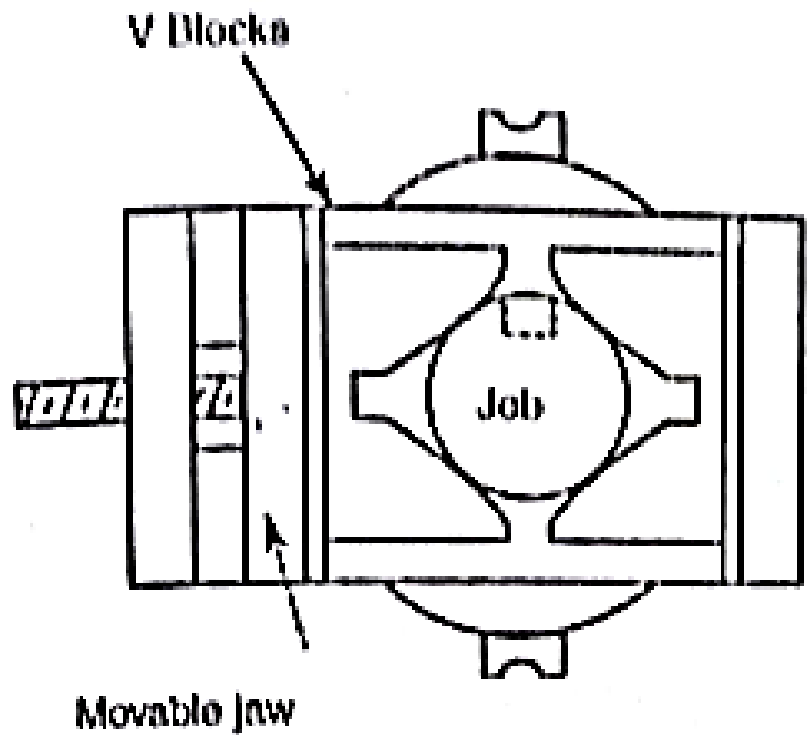

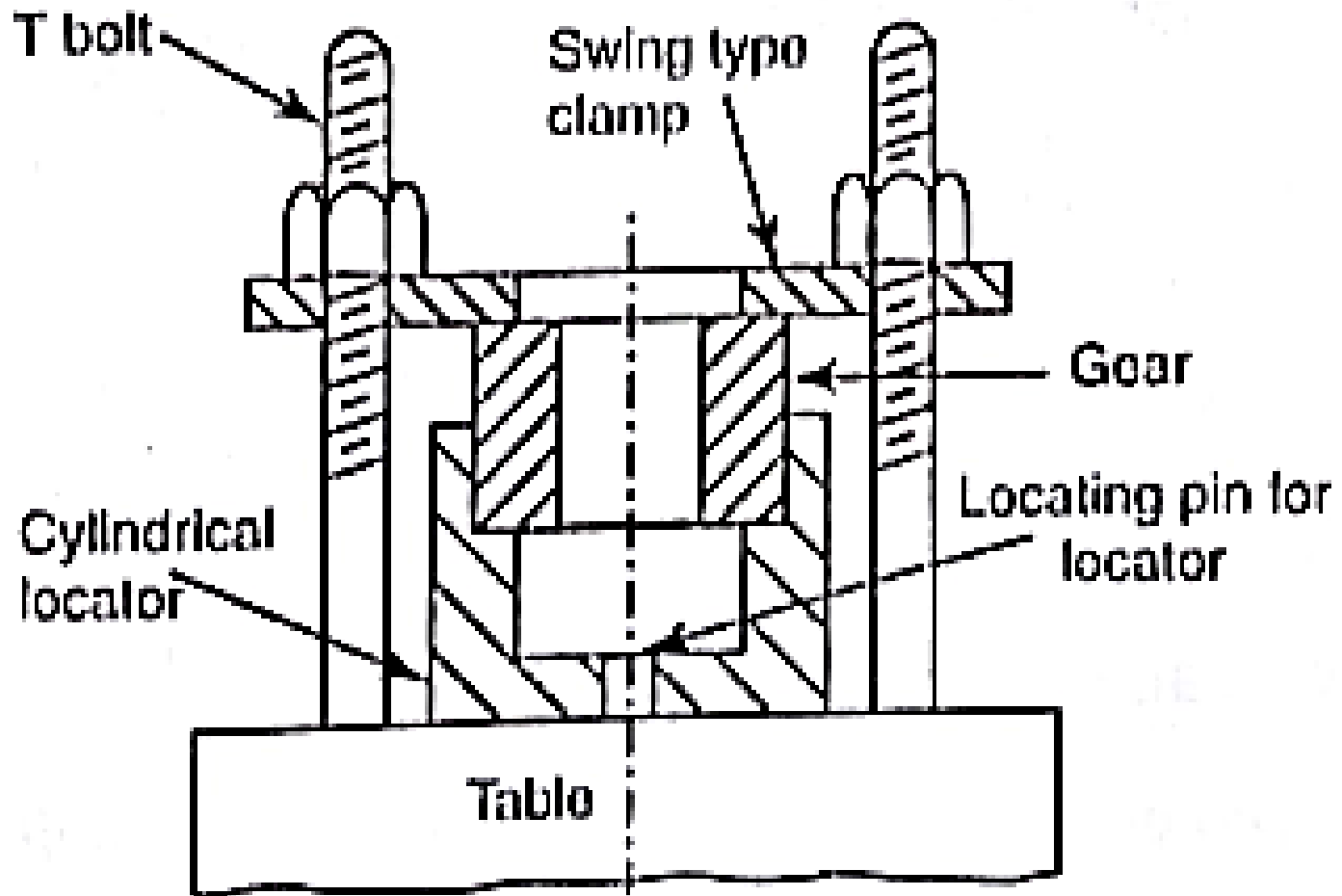

Slotting fixture

FEED MECHANISM

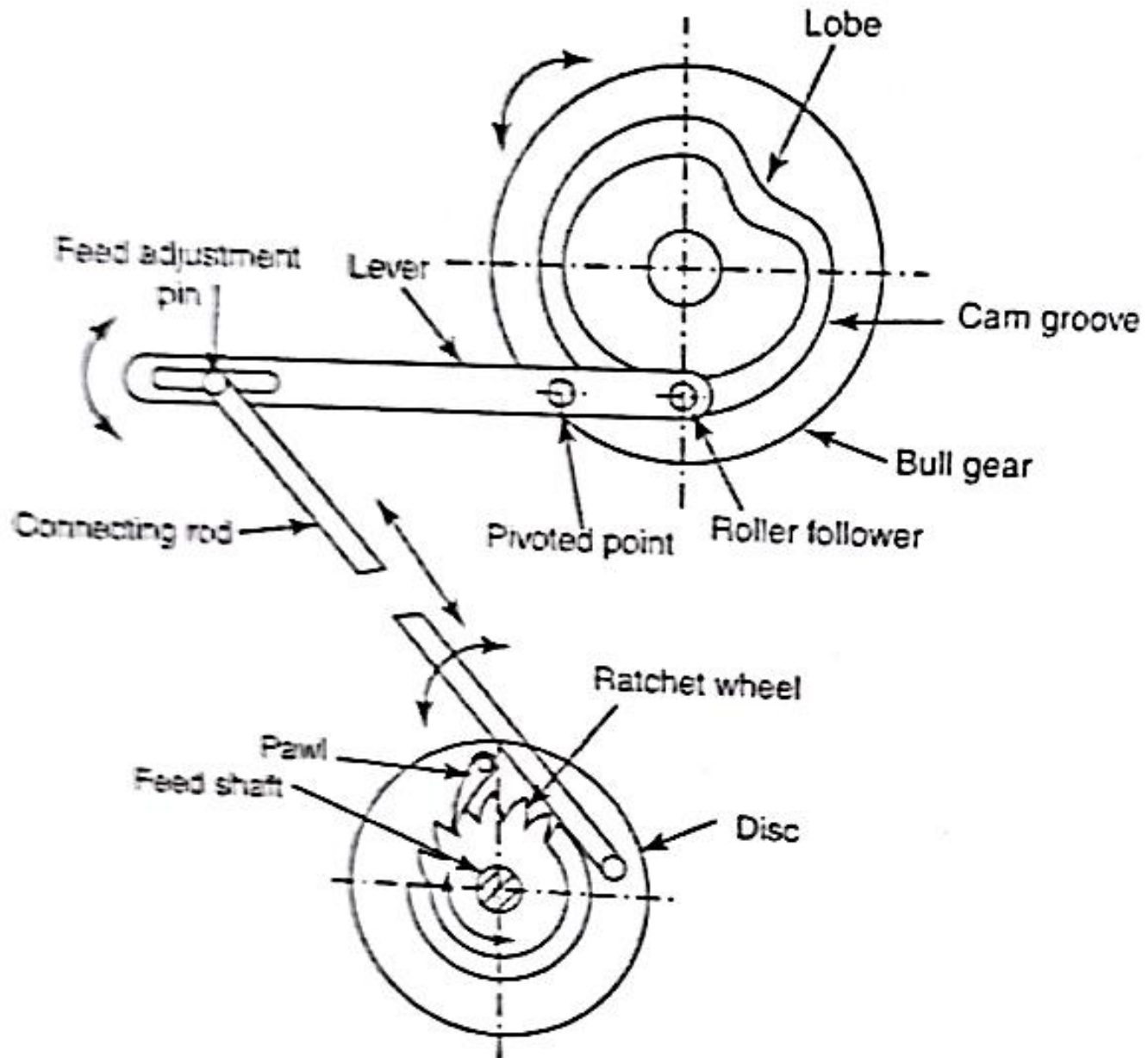

Slotter operations

The following operations can be performed on the slotter

- ❖ Cutting of internal grooves or key ways
- ❖ Cutting of internal gears
- ❖ Cutting of recesses

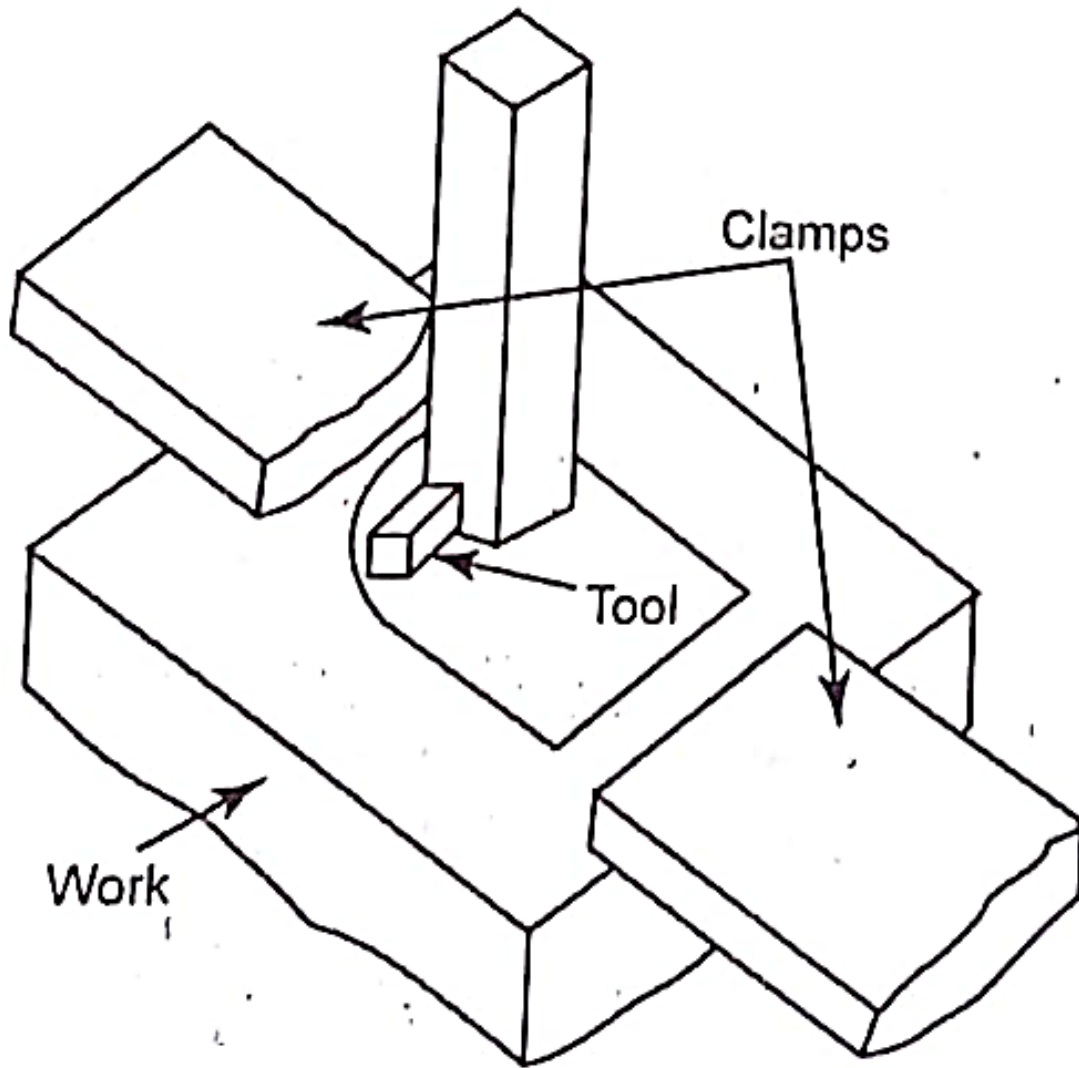

Machining curved surface

Example 7.1 Find the machining time required for machining a surface 600×800 mm on a shaping machine. Assume, cutting speed as 8 m/min. The return-to-cutting time ratio is 1 : 4, and the feed is 2 mm/double stroke. The clearance at each end is 70 mm.

Solution: Given

$$L_j = 600 \text{ mm}, \quad w = 800 \text{ mm}, \quad v = 8 \text{ m/min},$$

$$m = \frac{1}{4}, \quad f = 2 \text{ mm/stroke}, \quad c = 70 \text{ mm}.$$

From Eq. (7.2), we get

$$\text{Length of stroke } L = 600 + 2 \times 70 = 740 \text{ mm}$$

Substituting all the values in Eq. (7.5), we get

$$t = \frac{740 \times 800 \times (1 + 0.25)}{1000 \times 8 \times 2} = 46.25 \text{ min.} \quad \text{Ans.}$$

Example 7.2 Estimate the time required to machine a cast iron surface 250 mm long and 150 mm wide on a shaper with cutting-to-return ratio of 3 : 2. Use a cutting speed of 21 m/min, a feed of 2 mm/stroke and a clearance of 25 mm. The available ram strokes on the shaper are: 28, 40, 60 and 90 strokes/min. Also, determine *MRR* assuming depth of cut as 4 mm.

Solution: Given

$$L_j = 250 \text{ mm}, \quad f = 2 \text{ mm/double stroke}, \quad w = 150 \text{ mm}, \\ c = 25 \text{ mm}, \quad v = 21 \text{ m/min}, \quad d = 4 \text{ mm}$$

The cutting-to-return ratio of 3 : 2 gives $m = 2/3$
From Eq. (7.2), we get

$$L = 250 + 2 \times 25 = 300 \text{ mm}$$

From Eq. (7.1), we have

$$\text{Cutting speed } v = \frac{NL(1+m)}{1000}$$

From the above equation, we find number of double strokes N per minute as

$$N = \frac{1000 \times 21}{300 \left(1 + \frac{2}{3}\right)} \cong 42 \text{ strokes/min}$$

Nearest available ram stroke is 40 strokes/min which is very near to the calculated value. Normally, we should not exceed the specified cutting speed, as it will affect the tool life adversely. Hence, select $N = 40$ strokes/min.

With a chosen value of N , we cannot use Eq. (7.5) for time calculation. Hence, substituting all the values in Eq. (7.6), we get

$$t_s = \frac{150}{40 \times 2} = 1.88 \text{ min} \quad \text{Ans.}$$

From Eq. (7.7), we calculate the MRR as

$$MRR = 2 \times 4 \times 40 \times 300 \left(1 + \frac{2}{3}\right) = 1,60,000 \text{ mm}^3/\text{min} \quad \text{Ans.}$$

18. Determine the machining time required to machine three finished stocks of size $75 \text{ mm} \times 150 \text{ mm} \times 250 \text{ mm}$ each from raw stocks of size $80 \text{ mm} \times 155 \text{ mm} \times 255 \text{ mm}$. Stock should be removed equally from all faces using the following data:

Cutting speed = 35 m/min .

Maximum depth of cut: for roughing = 2 mm , and for finishing = 1 mm

Feed: for roughing = 0.5 mm/stroke , and for finishing = 0.3 mm/stroke

Cutting-to-return time ratio = $3 : 1$

Total clearance = 50 mm .

19. The 400mmX250mm face of cast iron block of size 400mmX250mmX 100mm is to be rough machined using HSS tool on a conventional crank shaper. Estimate the machining time assuming an average cutting speed of 20m/min and a feed of 0.2 mm/stroke. The cutting time to return time ratio is given to be 1.5 and the ram cycles available on the shapers are 28,40,60 and 90 per minute. Ans: choosing 28 strokes/min, time=44.65 min